



25 IMPORTANT CONSIDERATIONS WHEN BUILDING A BLAST FACILITY

SPECIAL REPORT



03	INTRODUCTION
07	THE BLAST POT PACKAGE
11	THE BLAST ROOM
13	THE DUST COLLECTION SYSTEM
17	THE ABRASIVE ELEVATING AND SEPARATION UNITS
20	UNDER FLOOR RECOVERY SYSTEMS
23	THE COMPRESSOR AND AIR SUPPLY EQUIPMENT
25	THE OPTIMAL ABRASIVES

Two blasters blasting a bridge girder in a very large blast room.

INTRODUCTION

BUILDING A PROFITABLE BLAST FACILITY

Let us now go over the various systems used in a blast room. The functions of each system are discussed, and the different types of equipment available for the function are listed. It is noted, as we go through this guide, that for most systems, the most cost-efficient system is the one highlighted. Such is because the cost difference between systems is initially not nearly as great as the cost difference of running those systems.

MAIN FEATURES OF A PERFORMANCE BLAST ROOM

There are five main components in a performance blasting chamber.

1. The chamber itself includes lights, rugged doors, and is typically lined with heavy duty steel plate on all surfaces to resist abrasions from ricochet. The room must also have correctly sized air entry and exit plenums for efficient ventilation without allowing abrasives to escape.
2. The dust collection and ventilation system provide sufficient airflow in the blast room keeping dust levels low, increasing operating visibility, and quickly clearing the room of dust when blasting ceases.
3. An abrasive recovery system – commonly underfloor – conveys the spent abrasive to a central point for recycling and cleaning. An efficient system will recover automatically from all or part of the floor, depending on the design.
4. The abrasive recycling and cleaning unit will clean the used abrasive by separating dust, fines, paint flakes, and trash from the good reusable abrasive. The abrasive is then stored – ready to use again.
5. Blasting pots, hoses, and nozzles are selected to suit the blast room function. Typically, multiple outlets are installed to allow more than one operator to blast continuously.

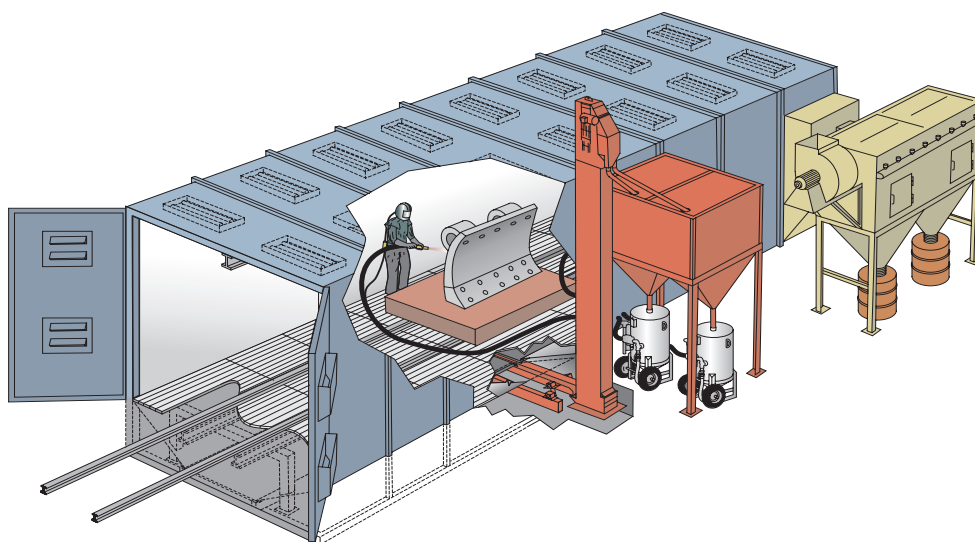

BLAST ROOM WITH RAIL TRACKS INCREASES PRODUCTIVITY FOR MATERIAL HANDLING

WHY INSTALL A BLAST ROOM?

There are several advantages gained by installing a blast room – both economical and environmental. Weather constraints are no longer a problem. You can blast continuously for 24 hours a day for a whole year allowing you to achieve higher productivity and meet customer deadlines. The controlled environment assists your blaster to achieve a consistent quality of work.

Typically, blast rooms will incorporate an automatic abrasive recycling system which allows the use of recyclable abrasives while reducing your costs drastically. Not only do you reduce the purchase costs of abrasive but you also reduce handling and disposal costs. When containing all your dust from your blasting operation, your general site environment is cleaner, tidier and your neighbors are happier too!



READY TO ROLL IN A NEW BLASTONE BLAST BOOTH!

RECOVERY SYSTEMS

Recovery systems range from 100% area underfloor systems to simple sweeping hopper systems. A recovery system that has 100% floor recovery allows maximum productivity as operators never need be involved in handling spent abrasive. *(An alternative to this is a 25% or 50% floor area recovery system that requires daily operator sweeping to recycle all abrasives).*

When the spent abrasive falls through the floor grating, it is collected by a conveyor, typically an oscillating tray conveyor which transports the abrasive across to a bucket elevator and an abrasive cleaning station. Oscillating tray conveyors are a reliable, self-cleaning, low maintenance, and a low-profile solution to an efficient underfloor recovery requirement.

DESIGN AND CONSTRUCTION OF BLAST ROOMS

A blast room is a vital part of the industrial coatings industry. It is necessary to bring raw-off-the-mill and fabricated steel to a suitably clean finish and ready to receive a protective coating. In most instances, a 'profile' is imparted to the surface to provide a 'key' so that the paint film will adhere well.

The idea of directing a blast of high velocity abrasive at any object grew from the days when anyone who had a compressor and some type of pressure vessel could direct some form of abrasive at work, however, the abrasive was not recoverable. Using a blast room changes this equation, the main reason someone installs a blast room is to be able to recover and recycle their abrasive. This stops the process from becoming too expensive and wasteful.

In a blast room, dust can be controlled by proper ventilation; good lighting allows the operator to see clearly, producing a constant work quality and

where blasting can be done 365 days a year without being interrupted by weather conditions, dew, etc. Such as with an absolute minimum of manual labor.

To ensure high production and low maintenance from blast rooms, it is essential they were carefully designed. Walls should be constructed from 5mm steel plate suitably stiffened to prevent buckling. All interior surfaces should be free from any protrusion inside the chamber to avoid collecting dust and abrasive. Lighting is of paramount importance to provide sufficient visibility levels for the operator to easily see inside angles, corners, cleats, and around complex fabricated items. Lights should not be mounted inside a blast room. Doors should be open to allow full access to the room to utilize the entire size of the chamber. Floor grating and the associated support structure should be engineered to handle the loading levels as necessary. Typically, 50-ton loadings are easy to accommodate.



RUGGED AND DURABLE CONSTRUCTION

BLAST ROOM DUST COLLECTORS

A dust collector is a vital part of any blast chamber. It provides ventilation inside the chamber, and it removes contaminants from the exhaust air. It is essential that the dust collector was carefully selected to suit the size of the blast chamber, to maintain visibility and the required air velocity in the room. In general, the larger the cross section of the blast chamber, the larger the dust collector.

BlastOne can assist in all design and engineering calculations. Both wet and dry-type dust collectors could be provided.

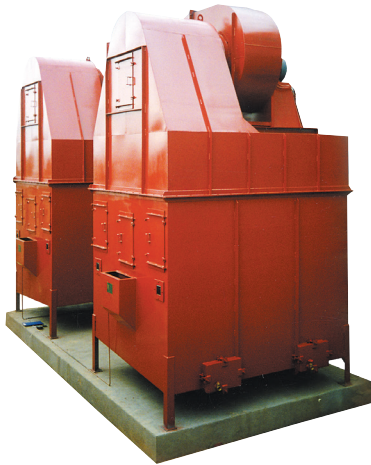

WET TYPE DUST COLLECTORS

Wet type dust collectors use water to scrub the dusty air and collect the dust as a sludge.



DRY CARTRIDGE DUST COLLECTORS

Dry Cartridge Collectors offer high efficiency dust filtration. Dust is trapped on specially designed cartridges which are automatically cleaned by a Smart Pulse™ cleaning system. Dust is collected in bins for easy disposal.

DON'T BUILD A RIG, PLAN A SYSTEM

These words by American blast equipment consultant A.B. Williams are so true – “Blast rooms, more than any other piece of equipment, tend to be built as a rig with little or no design input other than perhaps having seen someone else’s ‘rig’ or from some vague photograph in a sales brochure. Often, with just a little foreknowledge, a room can change from an inefficient rig to an effective asset”.

With this in mind, this guide is written. However, there are many important aspects which are too difficult to cover. For instance, the type and capability of dust collector fans; you may get someone who will supply a fan capable of 10,000 cfm, but won't suit a dust collector which must continue to put out 10,000 cfm even when the filter medium is partially clogged. Unfortunately, some manufacturers cut corners with equipment which does not perform as expected, or fail to tell you about how much the equipment will cost to run. This guide is a brief outline of the basic design concepts.

It is essential to understand that each component within a blasting facility has its effect on the economics of running a blast room. For instance, poor lighting, poor dust collection, or poor airflow design will increase blast time on each job. If you take 20% longer to do each job, wear and tear increases 20%, consumption increases 20%, power consumption increases 20%, labor increases 20%, but you don't get something of additional value in return for performing such job.

1

THE BLAST POT PACKAGE

HIGH PRESSURE AND HIGH PRODUCTION

1. THE BLAST MACHINE

At the heart of a blast room facility is the blast machine itself. This is a pressure vessel with means of loading abrasive through an opening in the top. An abrasive metering valve on the bottom allows the abrasive to fall by gravity into the airstream from the compressor in the 'pusher line.' This, in turn, travels at great speed because so much air is forced through a comparatively small orifice along the blast hose to the blast nozzle where the velocity of the air and abrasive increases dramatically and abrasive expelled at a very high velocity from the work surface.

2. THE REMOTE CONTROL SYSTEM

The other element of the blast pot is the remote control system. It allows the operator to start the blast using a valve (known as the deadman handle) strapped to the blast hose near the nozzle. This valve must, by law, automatically shut the blast machine down if the valve is released and lock in the 'off' position. The deadman handle actuates a valve on the blast pot which controls the flow of compressed air to the nozzle and the release of abrasive from the hopper.



SCHMIDT BLAST MACHINES ARE RECOGNIZED AS AN INDUSTRY LEADER

3. MOISTURE REMOVAL

A moisture trap is commonly fitted to the incoming pipework. It, besides removing moisture, will remove a certain amount of oil (if present) and will remove particles from the air. It is important, as particles in the deadman control valves can cause malfunctions. After the moisture trap, a pressure regulator is sometimes fitted to control the blast intensity.

Important note: The temperature of air passing through the moisture trap has a direct relationship to the amount of moisture removed; moisture traps cannot take moisture out of hot air; air coolers are available to increase the efficiency of moisture removal. Most abrasive flow problems are caused by moisture condensing on the internal wall of the blast pot.

4. THE BLAST MACHINE CONE

The cone at the bottom of the hopper should have sloping sides at approx 40°–45° to ensure that all of the abrasive will flow out.

5. THE ABRASIVE METERING VALVE

The type and design of the abrasive metering valve are important. Many valves are just not suited to use with all abrasives. The best valves have a short abrasive flow path and can be easily adjusted to very fine settings. Too much abrasive can slow the blast operation, just as much as too little abrasive can.



MICROVALVE III

Save time and money by installing a new MicroValve 3 on your blast pot today

6. PRESSURE LOSS

Pipework size is highly critical. A guide is that a pot with 1" pipework will satisfactorily handle up to a 1/4" (No. 4) nozzle; although a 5/16" (No. 5) will be used but with increased pressure loss. It is recommended that all nozzle sizes from 5/16" (No. 5) and larger use blast pots with 1 1/4" pipework. For high production blasting, 1 1/2" is recommended for No. 7 and No. 8 nozzles.

The design of fixed pipework between the compressor and blast pot is very important as all tee-offs, elbows, bends, etc., will cause small, but not insignificant, pressure loss. Refer to BlastOne's catalogue for details on pipeline designs.

Moisture traps and remote control valves must be capable of passing air with minimal pressure loss. 1/4" (No. 4) nozzles should use at least 1" moisture traps and valves. 5/16" (No. 5) and 3/8" (No. 6) nozzles should use 1 1/2" moisture traps with large element size and 1 1/4" deadman valves. (Do not use 1 1/2" or 2" moisture traps with small elements in this industry). 7/16" and 1/2" nozzles require full flow 2" ported moisture traps. We recommend a non-element type, e.g. high volume 2" moisture separator – stand mount.

Care in selection of remote control valves is warranted, as many with 1 1/4" connections are restricted by small 1" internal passages resulting 5-10 psi pressure loss across the valve itself. We recommend 1 1/2" valving where 7/16" and 1/2" nozzles should be used.

7. HOSE COUPLINGS

Air control valves and metering valves are available with up to 2" air passages where very high air volumes are needed. Air and blast hoses for the incoming air must be large enough. Jackhammer style ('A' type) couplings and hoses to 1" are suitable for up to 1/4" nozzles.

Do not use these types of couplings for 5/16" nozzle or larger! Surelock (or similar) 1 1/2" couplings and hose are suitable for 5/16" (No 5) and 3/8" (No 6) nozzles. Surelock couplings are about three times the size of 'A' type couplings and provide a very

little flow restriction. 2" Surelock or BOSS nut & tail couplings and hose are ideal for 3/8" and 1/2" nozzles (No. 7 & 8).

The air supply hose should never be PVC type hose, as such cannot handle the heat and oil and is dangerous. Use only premium synthetic rubber bull hose, and larger diameter should be used for any hose over 15m.

Use only proper static conductive blast hose as a blast hose. Using 1 1/4" standard blast hose is recommended over long lengths, and a 25' or 50', 1 1/4" Super Whip (lightweight) hose for the last length. Being lighter and more flexible is recommended for easier blast conditions.

Note: Always use as short as possible blast hose (i.e. don't use 100' of hose if 50' will reach). Not only will you be wearing out blast hose unnecessarily, but you'll also be getting a greater pressure drop!

In general, a blast hose should be 3 times the nozzle size and a bull hose (the air supply hose) 4 times.

8. BLAST HOSE FITTINGS

When selecting the blast hose, couplings, and nozzle holders consider the following points. ALWAYS use proper blast couplings, as any normal hose fitting that is not designed for blasting will become unsafe over time. Check couplings and nozzle holder gaskets regularly. Nozzle gaskets should be 1 1/4" bore for 1 1/4" hose and nozzle entry size. Deadman control hose lines should be strapped to blast hose every three feet. As a guide, 3/4" hose may be used with up to 1/4" nozzles, 1" hose may be used with up to 3/8" nozzles, and always use 1 1/4" or even 1 1/2" hose with larger nozzles

9. BLAST NOZZLES

Blast nozzles should be supersonic venturi type nozzles made of either tungsten carbide or silicon carbide.

Very important: Never fit or use 1" entry size blast nozzles on to 1 1/4" bore blast hose as blast speed will drop dramatically. 1 1/4" blast hose must have 1 1/4" entry size nozzle fitted.

Hint: Nozzle wear is easily checked by using an equivalent size drill bit, even 1/16" is a lot of wear. NEVER bash a blast

nozzle against the job as the sleeve can crack rendering the nozzle useless. Always measure blast pressure with a needle pressure gauge behind the nozzle. NEVER just assume that because you have 100psi at the compressor or at the blast pot that you have sufficient nozzle pressure. Pressure drops of 35 psi or more are regularly found on systems being used by unsuspecting operators.

10. THE BLAST HELMET

Blast helmets and filters must be approved by all relevant statutory authorities. Also, the helmet should be comfortable and quiet. Regulations require a thick inner lens. An outer disposable lens which can be readily replaced should be provided. If an inner lens of glass is used, a thick plastic lens must be used inside it; so that if the glass shatters, glass cannot injure the operator. Helmet air conditioners are effective in providing cool air to the helmet. Air conditioners that heat and cool are also available.



RBP NOVA 3 BLAST HELMET
The ultimate comfort and protection



RBP C40 CLIMATE CONTROL
Device for heating and cooling

11. REMOTE CONTROL SYSTEM SPEED

The deadman system should react reasonably quick with the operation of the deadman handle. If a quick start/stop is required, a Thompson Valve system should be installed. This system can include an extra control which allows the operator to stop the flow of abrasive and 'blow down' the job with just compressed air, also known as a 'remote abrasive cut-off' system. The release of the deadman will depressurize the blast pot and allow it to reload. If due to a long length of control hose, the reaction time is too slow, then a low voltage electric over air system may be installed.

12. COMMUNICATION SYSTEM

Excellent communication systems are available. The traditional cable type units have been more reliable as they are not affected by static electricity; however, advancements have been made with the wireless communication system, such as the NovaTalk system which suits the Nova 2000 and the Nova 3 Blast Helmet. Significant production increases can be realized if the operators can communicate freely with the supervisor without having to put down the blast nozzle and stop work.

2

THE BLAST ROOM

THIS SECTION COVERS SOME POINTS REGARDING THE LAYOUT OF THE ROOM, INCLUDING AIR INLET POSITION AND AIR EXHAUST. FOR MORE DETAILS ON AIR INLET AND EXHAUST, REFER TO SECTION ON DUST COLLECTION

13. THE BLAST ROOM

The first consideration that arises when discussing a blast room is the size. Don't make it too big! The suggestion is that four feet clearance on each side and above, the largest item you need to get into a blast room is generally considered about right. The critical thing here is to understand that the width and height particularly have a direct impact on the cost to establish initially, and the cost to run. Here's why. If a room of 18' wide x 16' high was built, you will have a cross-sectional area of 288 square feet, which means an 18,000 cfm dust collector would suffice. A 20' wide x 20' high room, however, requires at least 24,000 cfm. Not only is there a difference in original price between an 18,000 cfm unit compared to a 24,000 cfm unit, there is also a difference in the cost per hour to run. We suggest that 98% of all your work (including semi-trailers) will fit into an 18' x 16' room. This is probably the best size option and the other 2% can be done outside.

The same rule applies to the length. While the length will not change the size of dust collector required, you will have a larger floor area to recover abrasive from, so there will be added costs in the building of the room. The oscillating tray floor type of grit recovery will not make a big difference to

the running cost, but if you opted for a pneumatic recovery (waffle) floor, you will be paying quite a lot more to run the room in electricity charges (*refer to underfloor recovery floor section on page 20*). Of course, if your decision is to have a steel plate floor and manually recover abrasive, you may not want a room too large to sweep.

Many blast rooms are built with doors at each end. If you have enough area on your site for this, it is an option worth considering. It allows you to load the item to be blasted next onto a work trolley while blasting is in progress, then once completed, the blasted item can be moved out through the far doors into the paint section and the next item can be moved into the room, saving considerable time for the blaster. This option, of course, will have an effect on the location of the abrasive reclaim system and dust collector etc. Generally, doors at each end are built on the larger blast rooms.

14. MATERIAL HANDLING

Careful planning is also required regarding the means of handling of items to be blasted in and out of the room. The following comments may help.

A track-mounted work trolley system is the most common method used. Several trolleys are often provided; rails extend from within the blast room to

outside, and the work loaded by forklift or overhead crane and the whole item wheeled into the room. While blasting is in progress, the previous item blasted can be painted while on its trolley, and the next item to be blasted can be loaded onto its trolley. The trolleys often have 20+ ton capacity.

Forklift. Except for rooms with a steel plate floor, it appears, from observation over the years, that it is better to keep forklifts out of blast rooms. The high concentration of weight buckles the grid mesh quite quickly, and the ability for the back wheels to 'screw' the grid panels out of position has seen many forklifts wheeled through the floor.

An **overhead gantry crane** is sometimes used where the operators feel that they can satisfactorily crane the items to be blasted in. Usually, a wire rope passes through a long slot in the ceiling of the blast room, and the gantry is passing over the top of the room. Rubber flats along each side of the slot prevent the loss of abrasive. In most cases, operators end up using trolleys on rails to wheel the items into the room and the gantry is only used to load the trolleys while blasting is in progress, while it seems to be a slow process.

15. CONSTRUCTION MATERIALS

Construction materials regulations in most states prevent the use of certain materials including

masonry, rubber, sheet roof, and walling steels such as corrugated iron, trimdeck etc. Blast rooms are best made of mild steel plate walls, ceilings, and in the case of non-recovery floor rooms, the floor. A lighter plate is suitable for the ceiling, $\frac{3}{16}$ " for the walls and $\frac{3}{8}$ " are ideal for floors. Generally, it is good to erect the room inside a shed or workshop as it makes weatherproofing easier, which means the blast pot and abrasive separator can be out of the weather.

Generally, the dust collector is sited outside the building particularly in the case of larger units, even though it is quite satisfactory inside.

Important: Weatherproofing of the blast room, including the door areas, the blast pot, and abrasive handling equipment, is essential as a very small amount of moisture will clog the abrasive and steel grit as it will rust into hard lumps. Bear in mind that once blasted, it will be an advantage if you don't need to take the item out into the weather as the smallest amount of rain, dew etc. will cause a rust 'bloom'.

Floor grating for the standard duty blast room is typically made of 1" high steel grate panels – heavy industrial rooms will use 1 $\frac{1}{4}$ " high section grating. It is important that the underfloor support structure be carefully designed to cope with the maximum anticipated weight.

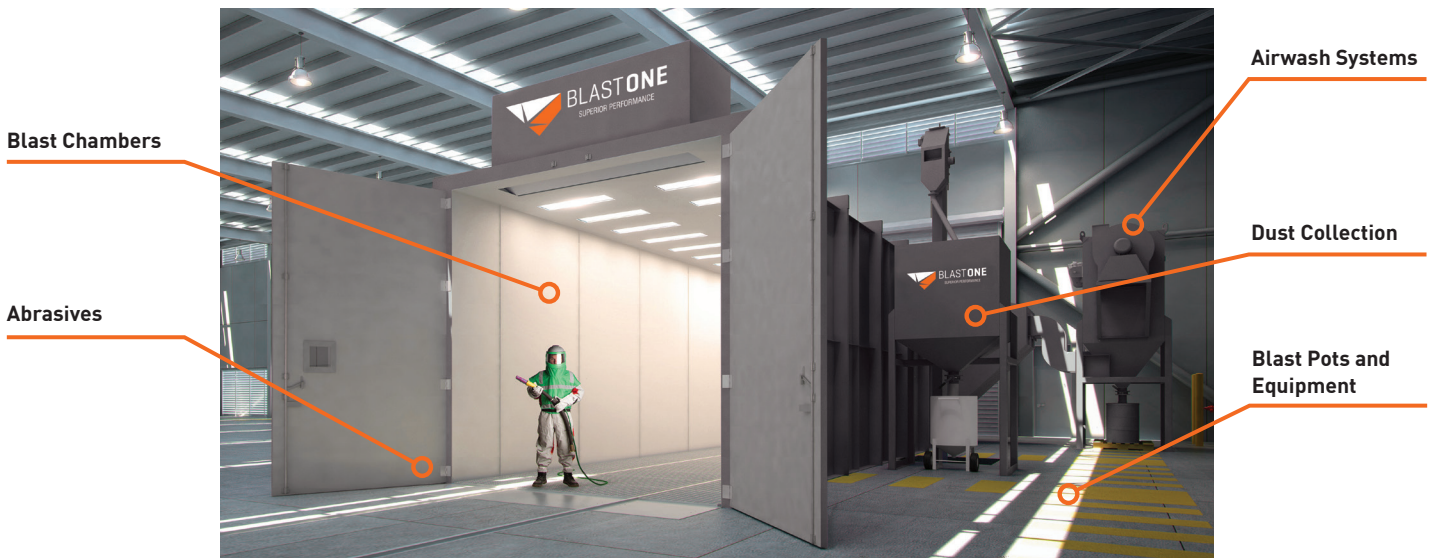

3

THE DUST COLLECTION SYSTEM

THIS IMPORTANT ITEM, REQUIRED BY STATUTORY AUTHORITIES, IS AN ESSENTIAL COMPONENT TOWARDS MAKING YOUR BLAST ROOM EFFICIENT

16. DUST COLLECTION

If you find it difficult to see inside a blast room because of dust, the lighting may be very good, but to be practical, each item can and does take longer to do because you will be going back over areas that have been missed. It is not uncommon for increased times of 25%. Usually, an operator does not realize just how much time he is losing until the problem is rectified.

The two main questions that need to be addressed to the dust collector are:

- What size (capacity) will I need?
- What type of dust collector will suit best?

The size of a dust collector is discussed on page 11 and it was noted, that the cross-sectional area was a deciding factor relating to the needed

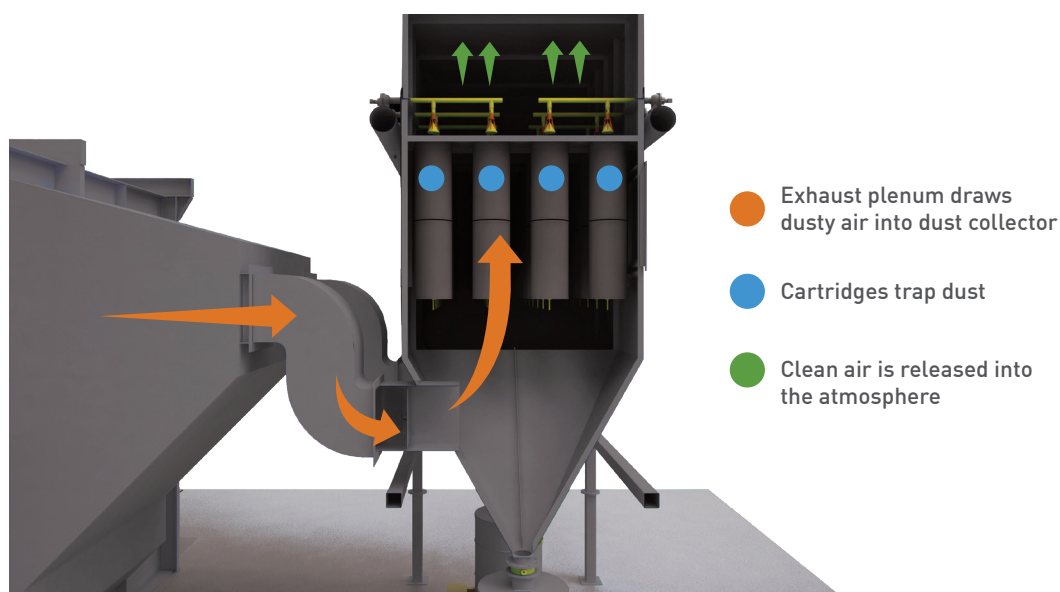

DIAGRAM SHOWS THE PATH OF THE AIRFLOW

capacity. For instance, we said an 18' wide x 16' high room had a cross-sectional area of 288 square feet (18 x 16 = 288). We also noted that an 18,000 cfm unit was sufficient. This was arrived at because if we were using garnet or steel grit, which by itself produces almost little dust, 60 feet per minute airflow is adequate. Thus, 288 sq ft cross-sectional area x 60 feet / minute flow = 18,000 cfm.

If we were to use a dusty abrasive in a blast room like copper slag, (*more common in rooms with no underfloor conveying systems*), 80 feet per minute would be quite adequate if you had a good quality abrasive separator, but 100 feet/min or greater would be recommended. It means that a 24,000 cfm dust collector would perform well in a 16' x 18' room.

Of course, if an abrasive such as slag were to be used in an enclosed blast room, you would

probably require somewhere between 120-150 feet/min. It means you would require 40,000 cfm at least to operate. This sized unit will consume more than double the original calculation of electrical power.

17. TYPES OF DUST COLLECTORS

Broadly speaking, there are two types of dust collectors that meet EPA guidelines. These are: wet scrub type units and dry reverse pulse element or cloth filter bag. Each type has its merits and its downsides. Some of the features that relate to each type are:

The wet scrub type dust collector can be used to any situation or abrasive. Not to be confused with water spray type units, the wet scrub passes the dusty air below water level, literally scrubbing the air.

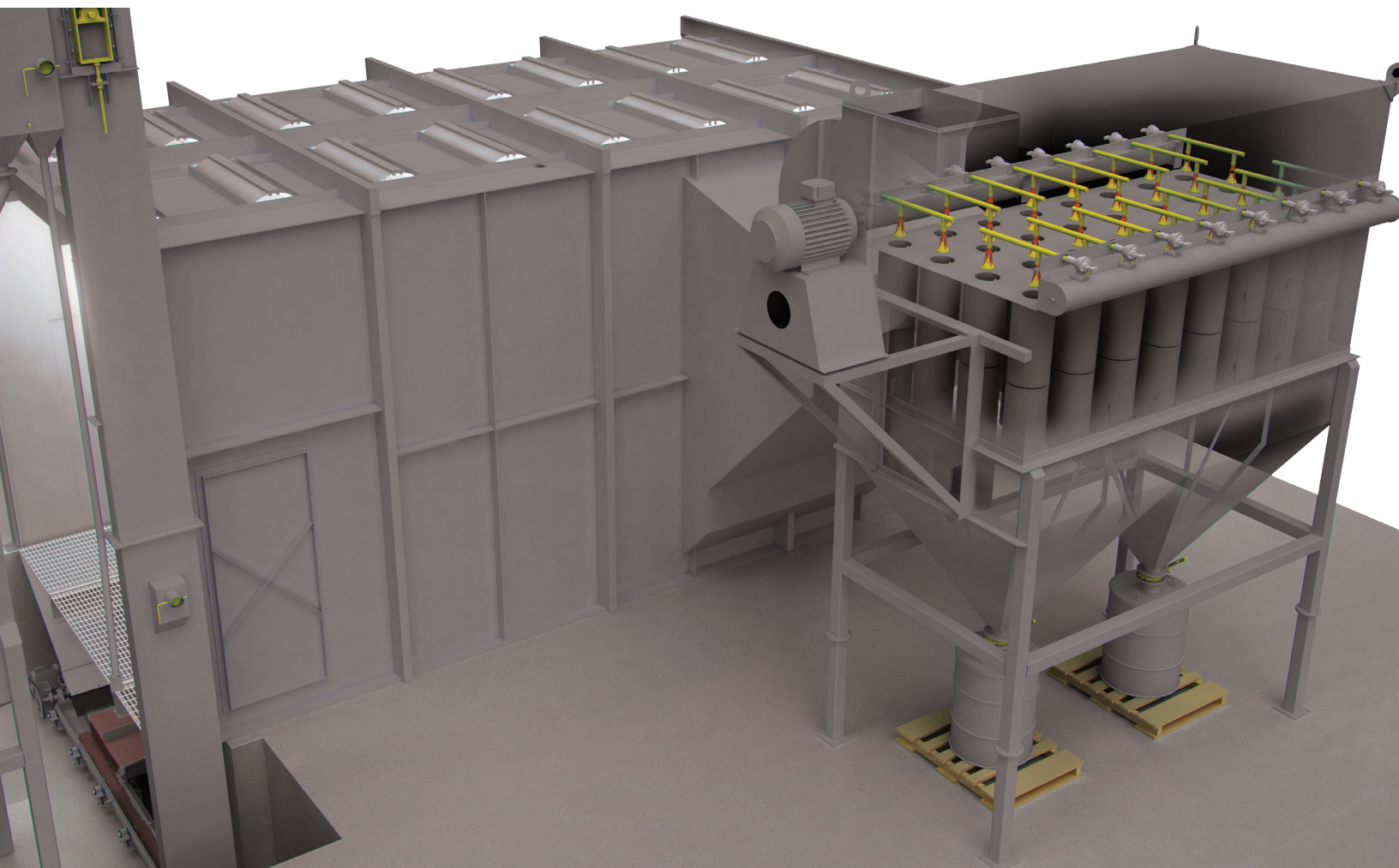

The dust is entrained in the water, and after passing a series of baffles etc., nearly all moisture is removed before being exhausted to atmosphere. It is not uncommon for a miniscule amount of mist to get through, so generally, it is exhausted outside the building. It also keeps noise levels down.

Wet type units can cope with large volumes of dust. Because there are no elements to clog, air flow remains fairly constant which is always important. In other words, the water can become extremely dirty before any appreciable difference occurs. A small amount of detergent added to the water helps prevent solidifying of steel dust in the water. Clean out is easiest if done regularly, and a truck with heavy-duty suction facilities used on water tanks or septic tanks makes a clean-out easier. Manual cleaning may be necessary to get the last portion out.

A wet type dust collector fitted with an underwater cooling coil will reduce compressed air temperatures, thus reducing troubles with moisture clogging abrasive in the blast pot. The other point about wet type units is that the initial purchase price is usually much less than dry-type units.

Running (power) costs are usually close to being the same as dry-type units.

Dry-type dust collectors have been used for many years. It is in more recent years that reverse pulse units have made these much more efficient.

Mechanical shakers have been employed to shake and loosen dust from filter bags when the dust collector is turned off. It is necessary as the fine dust clogs the bag, reducing airflow dramatically.

Reverse pulse is used in the case of bag type and element type collectors.

A sequential timer activates an air solenoid valve which sends a "shock" of compressed air through the element or bag in the opposite direction to air flow. If the shock is sufficient, dust which has accumulated on the outside will be released, and most should fall away, even while the dust collector is operating. It is an especially good idea to continue the pulse for several cycles after the dust collector fan is turned off.

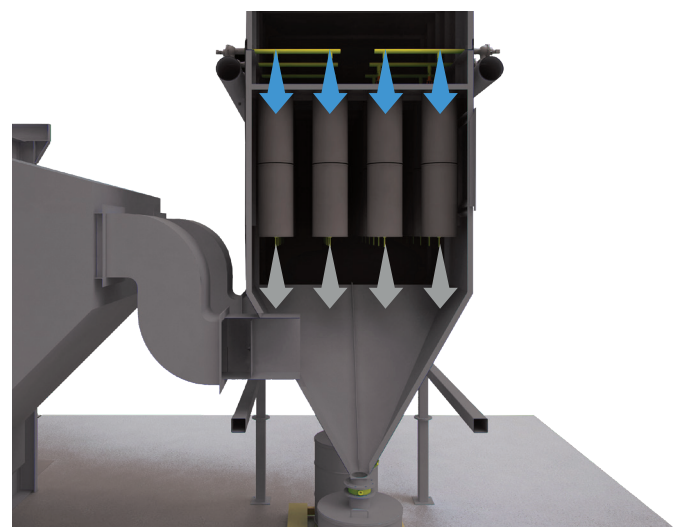
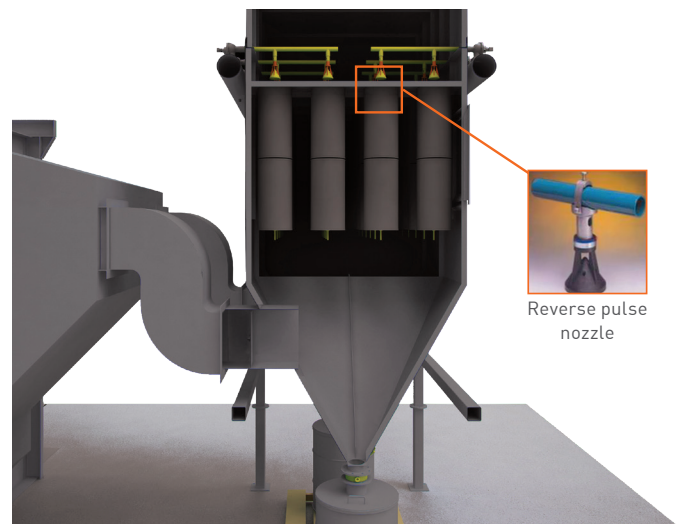

- Reverse pulse nozzles shoot compressed air through filter cartridges
- Dust fines fall into waste bins

DIAGRAMS SHOW THE ACTION OF THE REVERSE PULSE JET OF AIR

Today most dry-type units use elements, not at all, unlike large truck type air filter elements. (Automotive elements are not used as they do not provide the life or level of dust emission standards required). Whichever filter medium is used, the cost of replacement does need to be weighed up as the life of the elements/bag is a significant cost factor. Fines and dust will need to be disposed of regularly, and this can be a hazardous job.

Dry-type units are better suited to situations where dust concentrations are lower; hence, they are used in blast rooms using steel or chilled iron and not where high levels of dust are common from the items being blasted, i.e., from heavily rusted steel etc. Increasing the pulse frequency will help if dust generation is increased.

18. AIRFLOW WITHIN THE ROOM

This subject is one of the most important and least understood aspects of blast rooms. Planning the airflow within a room should be the next step after determining first the size; the position on the site; then where the dust collector is. Here are some tips:

- a. The air should enter the room at one end and exit at the other. If air enters on one long side and exits on the other long side, the speed of airflow will be low, unless you had huge or multiple dust collectors. If airspeed is low, dust will settle on the floor. Next time the blast is pointing in the dusty area, you will pick it up again, and again, and you will create your dust storm. This point cannot be stressed enough.
- b. The air inlet vents, therefore, will be at opposite ends to the dust collector. As it is common for the dust collector to be at the opposite end to the doors, the vents frequently are placed in the doors. It has the advantage of not forming dead spots where airflow is low, and dust will settle on the floor. If vents were on the roof just inside the doors, you would have a 'dead' spot where dust would settle just inside the doors. It is usual for vents to be positioned not far above floor level (up to 3'). Additional vents, of course, may be necessary and can be either higher up or on each side of doors on side walls. The inlet

air vents are best made so that air can pass in without undue restriction, (approx 1000 feet/min but so that baffles precludes abrasives from passing through.

19. EXHAUST PLENUM

The exhaust plenum is located at the opposite end of the room to the inlet air vents. If this unit is located on the end wall 'dead' spots will be minimized; however, it is sometimes necessary for the exhaust plenum to be on the side wall. If this happens, the corner opposite may form a low airflow 'dead' area. To overcome this, a small additional inlet air vent not far up from the floor will overcome this problem.

To lose even a small amount of good abrasive out through the exhaust into the dust collector will rapidly make the blast operation costly. The design of the exhaust plenum is critical. Abrasive blasted at the exhaust exit and passing into the exhaust plenum must be deflected: and speed reduced so that gravity can allow the particle to drop out and back into the room without the airflow carrying it out and into the dust collector. Hence, the exhaust plenum is also a critical element in the whole process of making the blasting facility as efficient as possible.

It should be noted that some rooms utilize the power of the dust collector to convey abrasive from 'waffles' under the mesh floor to abrasive separator. The dust collector in this case, obviously, needs to be massive to provide enough air speed to carry steel abrasive along (3600 feet/min minimum) the underfloor channels. Power consumption and cost to run this type need to be evaluated carefully (*see: Underfloor Recovery Systems on page 20*). Rooms with waffle floors typically have downdraft airflow which is the air entering inlet vents in the ceiling of the blast chamber.

4

THE ABRASIVE ELEVATING AND SEPARATION UNITS

RECYCLING YOUR ABRASIVE

20. DESIGN AND TYPE CONSIDERATIONS

Whether or not your blast facility is going to have a full floor area recovery or just a partial floor recovery, the problem remains that you will need to elevate the grit either before or after it is cleaned, separated, and dropped back into the storage hopper on top of the blast pot. Two methods are common in the industry: bucket elevators and pneumatic (airflow).

Of the two, pneumatic is, as far as cost is concerned, a little cheaper. Since you already have a dust collector sucking lots of air, why not utilize the airflow? Its advantage is that it is cheaper to supply and install initially.

However, its disadvantages are:

- Velocities must be high enough to carry abrasive. i.e., > 3600 feet/min hence wear particularly on bends tends to be high even with wear plates installed.
- Power consumption is high. Usually, this type of elevator is used in conjunction with a full or partial recovery waffle floor.
- Such systems are prone to clogging. If airflow drops or if too much abrasive is fed at one time, the weight of abrasive becomes greater than what the velocity of air can lift, thus, causes the system to bog down. Proper care and



RECYCLING SYSTEM IN A FULL RECOVERY BLAST ROOM

maintenance must be observed to prevent such from happening.

Bucket elevators have the disadvantage of costing a little more initially, but a bucket elevator cannot bog down once the flow control gate is set. You will need to replace the buckets every few years depending on usage.

Bucket elevator benefits include:

- low power consumption, usually about 1kW
- high transfer rate of abrasive (6-9 ton/hour)
- they cannot bog
- they are quiet
- minimal wear and low maintenance
- they match in with the 'airwash' separator

Augers are not used or recommended with abrasives. They are occasionally used by persons who build their room. Experience would dictate that high wear and be subject to failure due to high mass materials, make it hard to recommend. Steel grit also does not easily 'flow'.

21. ABRASIVE SEPARATION

Abrasive separators are necessary at some stage to separate the dust, fines, and trash from the good abrasive. In the case of pneumatic recovery, this can be done in two ways.

The abrasive is sucked up by the pneumatic pipe to a cyclone type separator, enters at high velocity and spins around the cyclone, losing speed, and

dropping down out of the high, velocity air area, and settles at the bottom where it is stored until the pop-up valve drops. It allows the abrasive to run into the blast pot ready to be reused. Fines and dust, however, are carried by the flow of air away from the circumference of the cyclone into an adjustable (usually) opening in the center onto the dust collector.

Once again, high velocities are required; hence, wear is often a problem. Cyclonic Separators will require frequent maintenance and regular inspection of the wear plates. Cyclonic separation is used quite a bit as these are your only option if you have a pneumatic recovery. It works moderately well if proper care is observed when making adjustments. However, a perfect separation is not usually possible; if you attempt to get rid of all unwanted fines, you will discover that you also lose an unacceptably high proportion of good abrasive. Another disadvantage with this system is that all dust and fines go to the dust collector; which means that you will load it up quicker and decrease your efficiency.

Another way is to suck the abrasive from the floor into a large plenum chamber where the abrasive

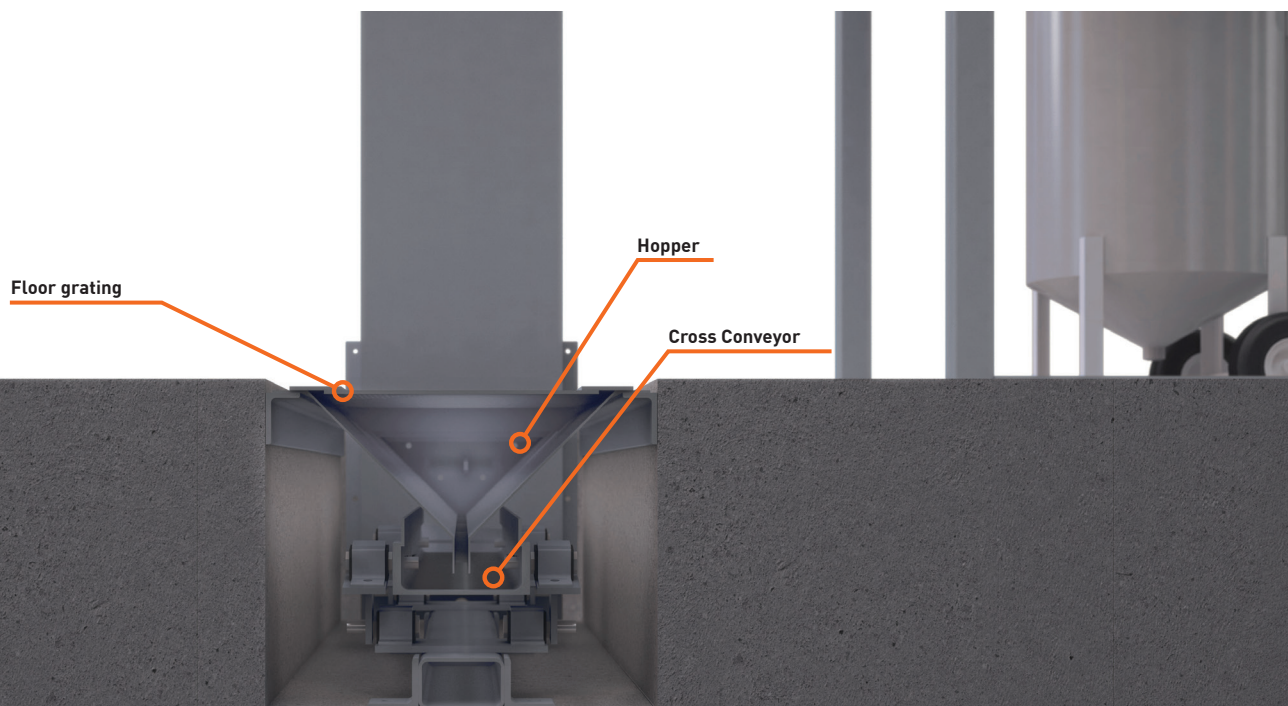

is slowed down and falls into a tube running along the bottom. Most of the dust separated at this point is being carried up high in the plenum chamber and into the dust collector.

Another type of suction unit draws the abrasive along the tube running along the bottom and up to a cyclonic separator on top of the blast pot.

The added advantage of this system is that you can achieve a little better level of dust separation. The disadvantage, apart from the high wear problems associated with high velocities, is that there is a further suction unit consuming more horsepower to operate. Once again, it is recommended to stop and calculate just how much it will cost to run that few extra horsepower each year. Electricity costs can make or break a blast operator.

The air wash abrasive separator/classifier unit is often used in conjunction with a bucket elevator. It utilizes the 'winnowing' principle – a comparatively gentle flow of air passes through a curtain or 'waterfall' of abrasive. This carries the dust out to the dust collector, the fines drop into another drum/skip, and the good abrasive falls into a chute which carries it to the storage hopper on top of the blast pot. It is hard to think of any disadvantages with this system; wear is low because of low air velocities, fines are not loading up the dust collector since those are falling into a separate skip, but the best thing is you can achieve a high class of separation.

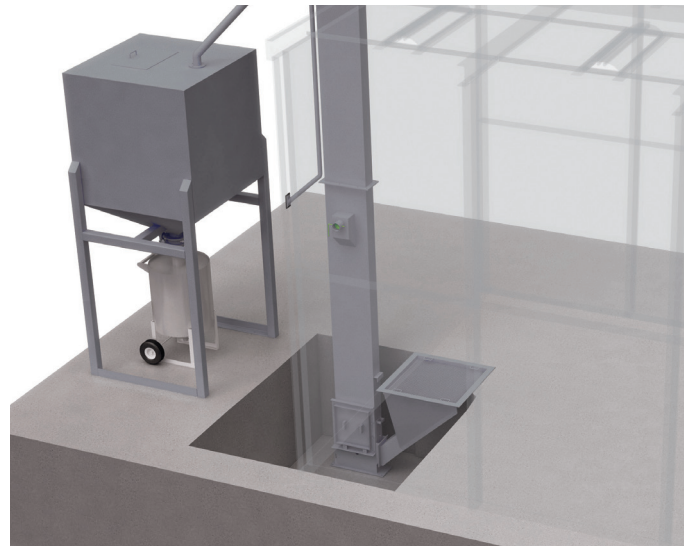

PARTIAL RECOVERY
This is a sweep in hopper

Very little dust will find its way back into the blast pot, thus, reducing dust levels within the blast room, and you will not be disposing of good abrasive. You can simply adjust it so that you can keep abrasive, which has broken up but is still useful, or increase the airflow a little, and it will return only larger particles to the blast pot. This unit also is particularly useful if you change the type of abrasives in your blast room, as it can be easily adjusted to suit any different abrasive.

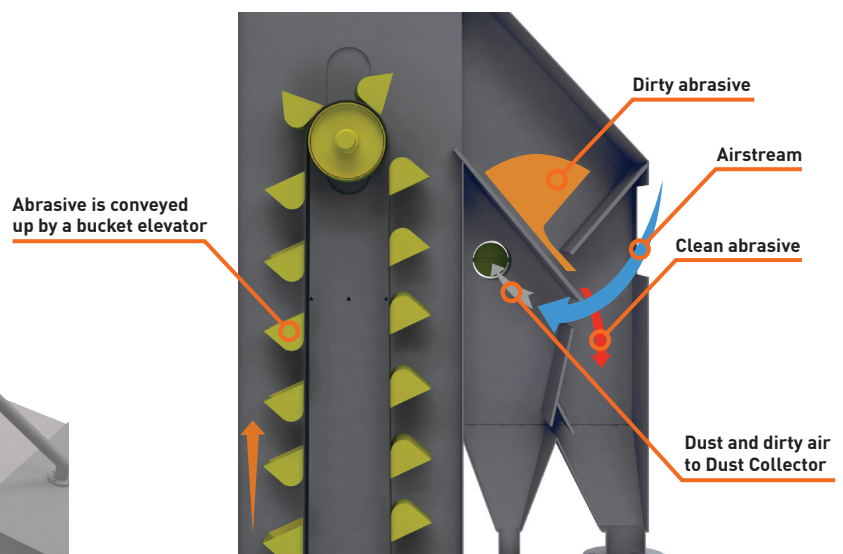
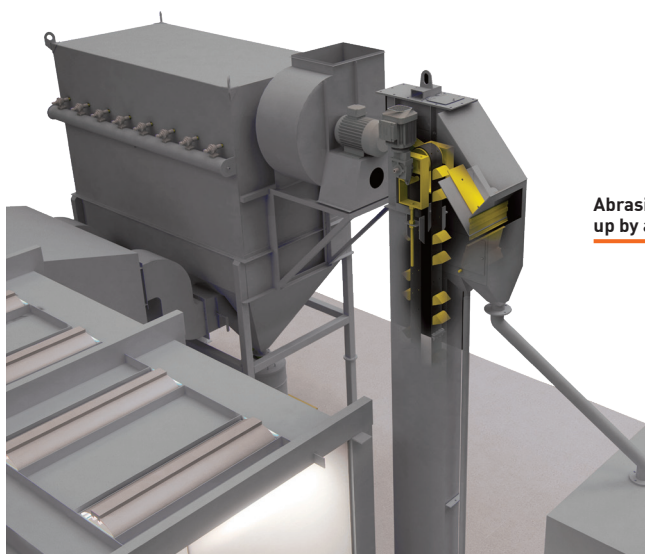

5

UNDERFLOOR RECOVERY SYSTEMS

THESE SYSTEMS ARE IMPORTANT FOR THE EFFICIENT OPERATION OF A BLAST ROOM

22. SYSTEM TYPES

If you are considering not to install a recovery system in your blastroom, you may be able to save some extra costs. If you wish to upgrade later on, you will save extra costs by some forethought as to the type and position of various items.

Underfloor recovery systems are installed to recover spent abrasive, convey it to the abrasive separation system, and onto storage; ready for reuse without any manual labor being required in the case of full recovery, or minimum labor in the case of partial recovery floors.

There are three main types of recovery systems used. These are:

1. Pneumatic 'waffle' type floors
2. Oscillating tray conveyor floors
3. Sweeper floors, augers, and conveyor belts

Perhaps, the first question that needs to be asked is what criteria will help me to decide which is best for my application? What disadvantages and advantages does each have?

Pneumatic 'waffle' floors are recommended for use only with the finer grades of steel grit. Chilled iron grit up to G17 or steel grit up to GL40 should be the largest grade used. Garnet will carry satisfactorily with pneumatic recovery. Waffle

type floors have several characteristics which are important. They do not require a deep pit; not that there is a big difference between a 20" pit compared to a 40" pit in cost, but in some areas, high ground water can be a problem. Pneumatic floors are generally a little cheaper than some other types. Some disadvantages are that because it is common for quite large quantities of abrasive to collect in the channels, therefore, it is not practical to change from one abrasive to another. For example, if you commonly used chilled iron grit and won a contract to blast with steel shot, you would be disappointed at the amount of cross-contamination. Or if you had a job which required the use of garnet, say on aluminum, you cannot change over without a major problem. For general blast work to get maximum blast speed you will probably use G12 or GL50, but if you had a contract which required a larger profile and you needed to use G24, you would be surprised how much mixture you will get. In a large blast room with waffle floor, it is common to have several (costly) tons trapped in there eventually

It is wise to consider how much energy costs are going to be. A medium blast room will require a dust collector with at least 10 kW; an extra 8-10 kW more power is needed to provide enough airflow to carry the abrasive, and roughly that's about \$4,000 worth of electricity per year or \$20,000 in five years!

Pneumatic recovery is quite commonly used in partial recovery rooms. Consideration is given to cost if there is a need to upgrade to full recovery at a later date. This would necessitate replacing the dust collector. Care needs to be observed to prevent small items from blocking the abrasive holes at the bottom of each waffle. A blockage means the removal of a grid section and digging out abrasive until the piece can be removed.

Waffle floors do not require daily or weekly maintenance, apart from clearing blockages. With time, the holes can become worn at the bottom of waffle. A piece of steel with correct hole size, tack welded over enlarged holes will restore airflow to normal.

Oscillating tray conveyors will perform well with all types and sizes of abrasives. They consist of a 'tray' underneath the grid mesh floor which runs along the length of the room. They can be anything from 1' to 6' wide and they are suspended at regular intervals along each side on special suspension blocks which have a base firmly fixed to the floor of the pit. The horizontal tray oscillates causing the grit to 'hop' along the tray to the abrasive elevator.

Rubber mounting blocks have been used for many years; they have the advantage that there are no bearings to wear out. The rubber mounting blocks should be checked annually and may need to be replaced every few years.



FULL FLOOR RECOVERY

The most efficient use of your time no manual labor in the recovery process

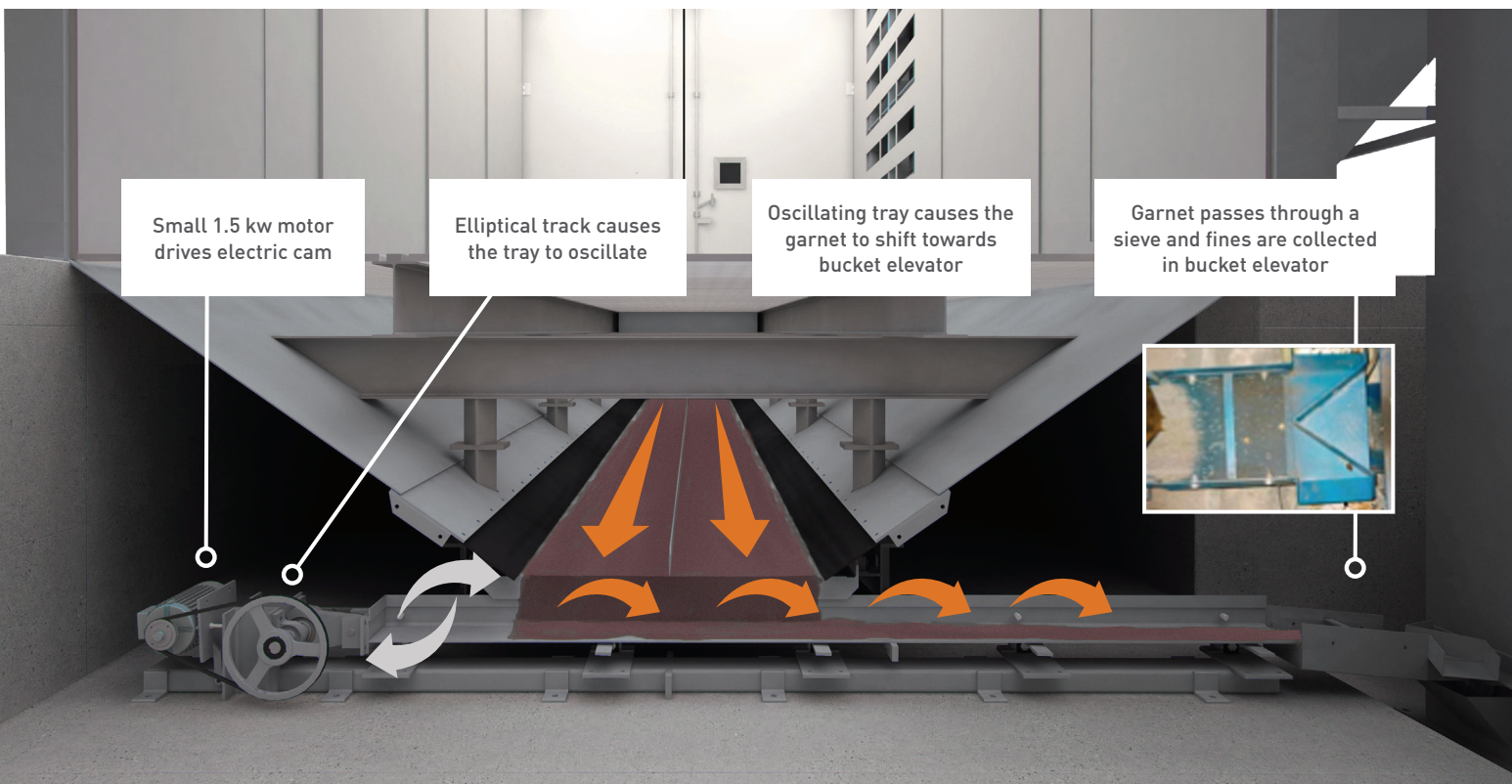

The main bearings on the eccentric are very reliable and have a prolonged life. The tray is usually made to a maximum length of about 60', which, is adequate for most rooms. The pit can be anything from 18"-72" deep.

The deeper the pit, the wider the room can be with a single tray. If a pit is 150" deep with a 72" wide tray, the room can be about 18' wide. Sloping hopper plates at about 35-40° direct the grit from each side and onto the conveyor in the center.

Generally, the cost to dig and concrete a 60" deep pit is not a lot more than a 20-30" deep pit. For this reason, a decision on whether to use this system is not usually based on any cost difference between this system and others, as the advantages outweigh any savings that could be made with a shallow pit. In high groundwater areas where the pit cannot be too deep, or if a very wide room is needed, it is customary to use two oscillating conveyors side by side.

If the blast room only requires one tray and the doors are at one end only, then the oscillating tray simply can convey the abrasive directly into the bucket elevator. A 'live' sieve at the end removes trash before entering the elevator.

The oscillating tray cannot be overloaded; even if someone were to dump a whole ton of steel grit on the tray, it would simply carry to the elevator without any problem. Within a few minutes, all of the grit will go through. It means that if you have to change abrasives, the abrasive is simply allowed to drain out of the hopper, clean the half shovel full out of the bottom of the elevator, clean the top of the blast pot of abrasive, and you are ready to drop the different abrasive on the tray with no cross-contamination. This usually takes about half an hour.

In the case of a blast room with two conveyors, side by side, the conveyors would carry the abrasive and drop onto a small cross-oscillating conveyor which carries the abrasive across the room to the elevator on one side.

Where a room is too long for one conveyor, it is customary for two conveyors to feed on either end

of a cross conveyor running across the middle of the room to an elevator halfway along one side of the room.

Sweeper floors, augers, conveyor belts have been grouped together in this publication as they are a form of conveying, which is being used less frequently. Although they use considerably less power than the pneumatic recovery systems, they have not achieved a reasonable standard of reliability, as these end up with broken cables, sweepers, and augers when jams occur. High wear due to the scraping action and dust in bearings are common. Tales of successful floors are the exception rather than the rule. Bear in mind that to be successful, a floor should not require undue labor to upkeep, the aim with recovery floors is to reduce the labor required to recover abrasive to almost nothing if possible.

It should always be remembered that abrasives are just that, abrasive. Also, abrasives don't 'flow' with sweepers or augers alike. These floors do not lend themselves to change from one type or grade of abrasive to another, as considerable quantities are left behind.

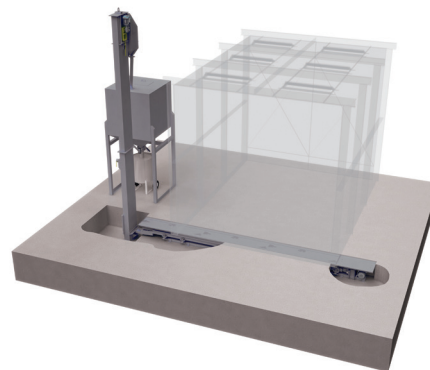

SINGLE CROSS CONVEYOR
For light use applications

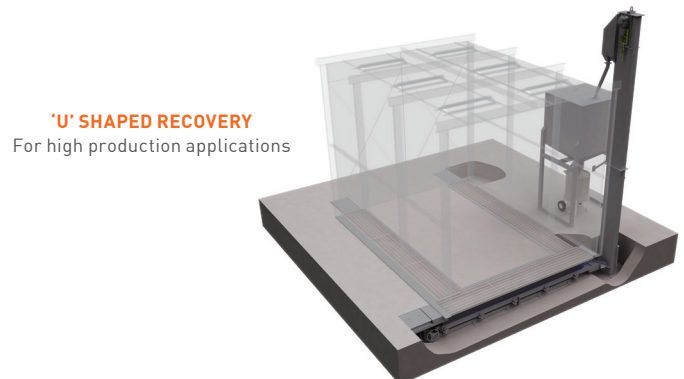

'U' SHAPED RECOVERY
For high production applications

6

THE COMPRESSOR AND AIR SUPPLY EQUIPMENT

KEEPING YOUR PRESSURE UP

23. COMPRESSORS

This section is not intended to deal with the various forms and types of compressors, but more about what the air requirements are for abrasive blasting and how we can get the maximum compressed air to the nozzle.

The first point to note here is that generally, a blast room operator will find an electric-powered compressor more practical and cheaper, as refueling and maintaining of a diesel motor are quite a consideration. Where power supplies are limited using a diesel unit can sometimes be necessary.

The next point is probably more important, except where abrasives are being used; which must not be used at high pressure (ie. plastic media, glass beads, stone fruit kernel or shells) as pressure plays an important part in the efficiency of a blast operation. Blast pressures should be around the 100psi (689kpa) mark, **measured at the nozzle**.

The pressure reading at the compressor or even at the blast pot may give a little idea as to what is happening at the nozzle.

Why is nozzle pressure important? Why measure at the nozzle? Isn't the reading on the pressure gauge which is in the blast pot accurate enough? If my compressor is showing 120 psi, what more could you ask for?

These and many similar questions are asked every day. The first rule of thumb here is to understand that for every 1 psi increase in air pressure over 80psi, you will gain 1.5% more production. Doesn't sound a real lot, but if you increase 10psi and do get a 15% rise in production, you will get about eight hours blasting done in seven hours. That is 1 hour less labor for one (or maybe two) workers, one hour less running time for the compressor (that is quite a saving!), 1 hour less running time on the Blast Room and ¾ hour less abrasive consumption (you will break the abrasive up a bit quicker). That sure adds up, doesn't it!

Referring to nozzle pressure, we understand that it is the pressure at the nozzle that provides the air, the abrasive particles, and the velocity we need. Refer to Section 1, where we covered essential items such as blast hose, blast pot pipework, moisture trap sizes, and also spoke about the 'bull hose', the hose from the compressor to the blast pot, etc.

A good set-up blast room compressed air supply will have full-size fittings on the compressor as long as the compressor is greater than 250 cfm 2" (50mm) minimum size threads full bore ball or stop valves, 2" hose tails. For 175 cfm to 250 cfm; 1½" (40mm) is the suitable size thread and hose tails. The hose from the compressor should lead to air cooler unit, or in the case of a wet type dust collector; air

cooling may be achieved by using a steel coil below the water level. An air receiver tank is not essential and plays little part in a successful blast operation; except that it usually will help a little if you do not have adequate air cooling. Bear in mind that all this should be in correct sized pipe and fittings.

24. AIR COOLERS/DRYERS

Air coolers take two main forms: **refrigerated units and heat exchange units**. Refrigerated units work well, but they cost quite a bit to buy and run. The other type is essentially a heat exchanger which looks similar to a large radiator with air blown through by a fan. These are successful enough, but the best types have a double heat exchange system; after it has cooled the air, removed the moisture in a moisture trap, the air is reheated; this type is very efficient. The relative humidity drops dramatically when reheated and moisture is not a problem.

Important note: Any moisture trap will not perform as it should if the air passing through it is too warm. Nearly all abrasive flow problems can be traced to moisture. After the air has passed through the cooler/dryer, it may be piped to the blast pot. If the air is cooled in a wet type dust collector, a moisture trap should be installed either on the blast pot nearby. It should not be necessary to have a further moisture trap if you have an air cooler/dryer system as it only will increase the pressure drop unnecessarily.

Getting back to our question earlier, why measure at the nozzle? The reason is that often the fittings, automatic valves, and even the blast hose that is too long/too small in the bore size will account for significant pressure drops. Always measure the pressure of the air as it comes out of the compressor (*always push the needle through hose at about 45° and in direction of the airflow*), then measure pressure behind the nozzle. Total pressure drop should be 5-8 psi maximum. It usually means the optimum pressure is obtained when the compressor is delivering 105 psi plus, measured when, and only when, the blast is in operation.

7

THE OPTIMAL ABRASIVES

CHOOSING THE RIGHT ABRASIVE CAN INCREASE YOUR BLASTING SPEEDS BY 50%

25. DIFFERENT ABRASIVE TYPES EXPLAINED

Many types and grades of abrasives are used and are required to be used in blast rooms. While the following guide is not exhaustive, it may help to put different abrasives in perspective.

STEEL GRIT AND CHILLED IRON GRIT

By far, the most commonly found blast medium in blast rooms, and all for good reasons. These abrasives can be recovered and re-used many times over and they produce almost no dust.

Steel being more malleable will tend to round over, and break up less and produce approx 25-50 cycles (*these figures can vary greatly depending on pressure and what type of substrate the abrasive is hitting*). Usually, the blast speed is slower as the abrasive rounds off.

Chilled Iron grit is cheaper (about 10%), is more common and the blast speed is achieved with finer, not coarser, grades. The exception to this is when very tough high build coatings etc., have to be removed.

Coarse grades are produced not to go faster, and generally they won't, all because the specification calls for a higher blast profile. Generally then, for normal structural steel work, the best and most economical grade is G-12 or G-17, and may be used

if a greater profile is required. If you use larger grades than these to get the profile required, it is most likely that you have an equipment (**possibly a nozzle pressure**) problem.

Steel and chilled iron are especially suitable for blast rooms with full recovery floors and most partial recovery floors. If you have a steel plate floor, it poses a problem to sweep and shovel if your recovery system is a long way down the room. Generally, steel and chilled iron grit is not to be used on aluminum etc., as it can leave impregnations in soft surfaces.

GARNET

Fast becoming the preference for most blast room applications, this versatile abrasive can be used on nearly any surface. Very fine grades produce excellent results on lighter alloys (*proper care needs to be observed to ensure buckling does not occur*) while premium grades produce an excellent profile and cleaning standards on virtually all surfaces. Blast speeds are generally higher than with steel abrasives. It is used quite extensively in blast rooms where there is no full floor recovery system because it is easier to collect than steel grit. It can be recycled up to between 6-10 times (*depending on blast pressure*), and while it produces more dust than steel, it is still considered a

relatively 'low' dust abrasive, which doesn't cause undue dust problems. With an efficient abrasive separator, dust levels should remain low even after many cycles.

ALUMINUM OXIDE

As a relatively 'low' dust abrasive, it will recycle several times more than garnet and will produce a good blast profile and cleaning standard. It is much more expensive, however, and it is not commonly used in blast rooms.

GLASS BEADS

Mostly used in cabinets, this product is generally not used in blast rooms. Used at lower pressures (50 psi approx.) it can be recycled around 10-20 times. It is used for low aggression applications requiring no profile and will produce a kind of polished effect. It can be used on cars, aluminum, etc. Larger grade sizes are used for peening and deburring.

COPPER SLAG

Copper slag is not used in blast rooms as it has limited recyclability. The very high dusting requires a large dust collector and this results in poor blast finish. This abrasive has specific uses in outdoor blasting, where permitted, requiring an expendable abrasive.

PLASTIC MEDIA

Excellent on sensitive surfaces but slow – mainly used for surfaces such as aircraft wings etc., where low aggression is required without stressing metal substrates. It can be used on cars with excellent results but because of high cost and low blast speeds is not common. Also, a special equipment is required.

WALNUT SHELL, STONE FRUIT KERNEL ETC

These blast mediums are being used successfully more and more on items such as cars where low aggression media is required. Cheaper than plastic media, it produces quite good results, but a special equipment is required.

STEEL & CHILLED IRON SHOT

These are used in a small number of cases of blast rooms where large castings are to be blasted. It is far more common in 'airless' blast operations. Shot, which is spherical steel, or chilled iron is commonly

used to clean up castings, removing the casting flash, foundry sand, and peening the surface in one operation. Because it doesn't produce a sharp profile, it is not so common for use on structural steel, however, if the kind of profile is not important, it can be used with low sized grades. Larger grades are typically used in peening operations.

GRANULATED PERSPEX ETC

This has evolved as the popularity of low aggression blasting increase. In some cases, good results are achievable, but care is needed in evaluating each product.

Most abrasives function favorably, but not all are economical. It is better to pay three times more for a product that produces more than three times the result. For instance, if you get four times the life and at the same blast speed, it will be to your advantage. Also, you may be better off paying three times as much for a product that only gives you 1.5 times the life, but 1.5 times the blast speed; **remember your running costs per hour is most likely to be greater than abrasive consumption (cost) per hour.** This is true for all abrasives and probably ranks as the least understood aspect of the abrasive blast industry. It's all about efficiency.

DISCLAIMER: The performance characteristics provided in this brochure only serves as a guide and that the results can vary widely on every project. Let BlastOne assist you on using the right abrasive and the right equipment for every project.

While care has been taken in compiling these notes, no responsibility is accepted by the compiler for any damage or loss, caused to anyone or any company accepting the advice or suggestion contained herein. It is your responsibility to be aware of regulations which Local, State, or Federal Government authority may impose.

©Copyright BlastOne 2017. All rights reserved.

The entire contents of this booklet are copyright. Photocopying, scanning, duplications or copying of pictures or information (except as permitted under the Copyright Act) is a breach of copyright and may result in legal action.

No part of this booklet may be reproduced or transmitted in any form or by any means, electronic, mechanical, photocopying, recording, or otherwise, without prior written permission of BlastOne.



BLASTONE INTERNATIONAL
4510 Bridgeway Avenue
Columbus Ohio 43219 USA

Toll Free 800 999 1881
Tel (614) 476 3000
Fax (614) 476 3002
Email sales@blastone.com
www.blastone.com

AUSTRALIA
Adelaide | Brisbane | Darwin |
Mackay | Melbourne | Perth | Sydney

NEW ZEALAND
Auckland | Christchurch

NORTH AMERICA
Columbus | Los Angeles |
Minneapolis | Chicago

UNITED KINGDOM
London