

ABRASIVE SELECTION GUIDE

YOUR SUPPLIER OF CHOICE FOR ALL ABRASIVES



A complete guide | Abrasives used in the blasting industry

Use this guide to help determine what abrasive is best for your project. The right choice of abrasive is crucial to ensure the most successful outcome possible. BlastOne supplies a range of abrasives for surface preparation projects.

FEATURES

- The basics of abrasive blasting
- GMA Garnet for tough jobs
- Abrasive specifications

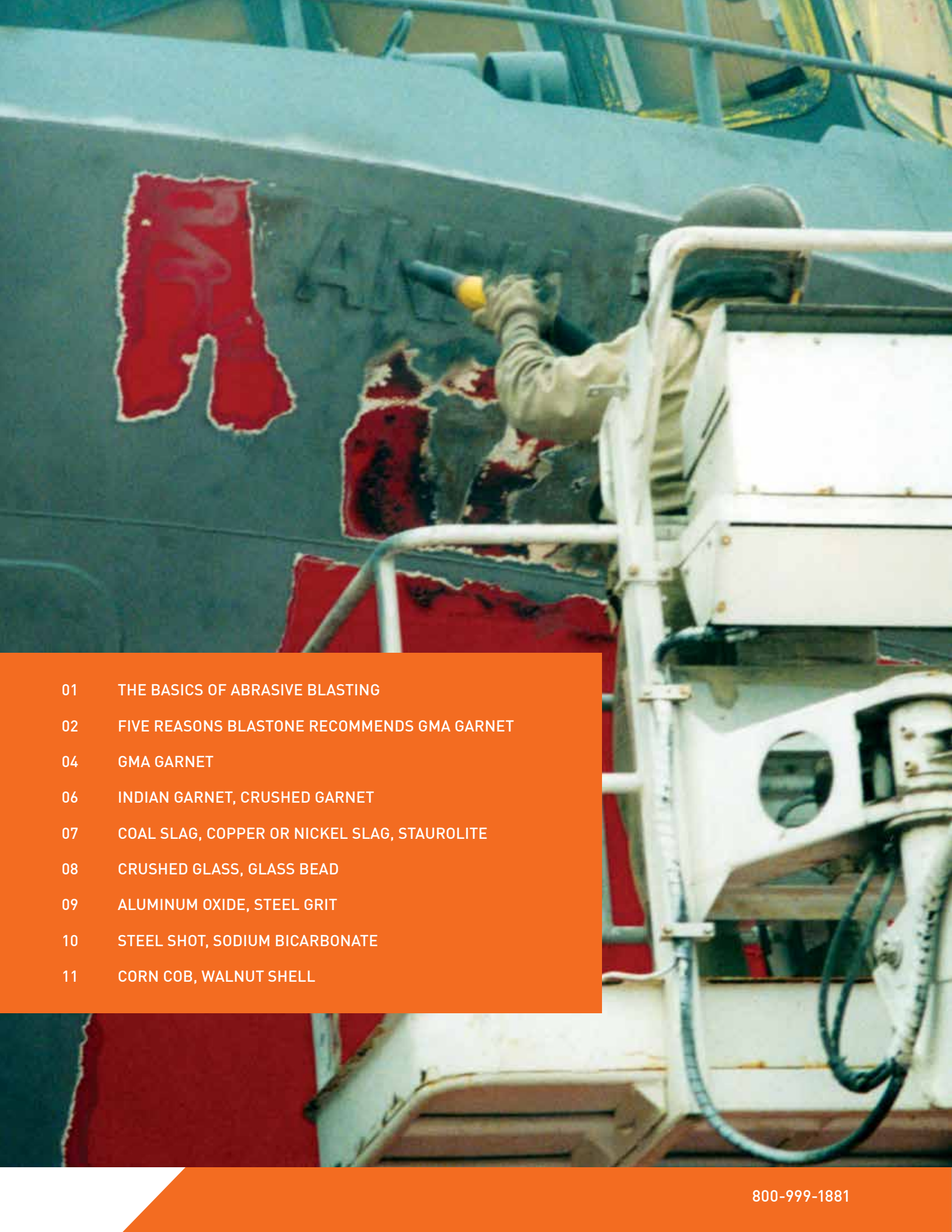

- 01 THE BASICS OF ABRASIVE BLASTING
- 02 FIVE REASONS BLASTONE RECOMMENDS GMA GARNET
- 04 GMA GARNET
- 06 INDIAN GARNET, CRUSHED GARNET
- 07 COAL SLAG, COPPER OR NICKEL SLAG, STAUROLITE
- 08 CRUSHED GLASS, GLASS BEAD
- 09 ALUMINUM OXIDE, STEEL GRIT
- 10 STEEL SHOT, SODIUM BICARBONATE
- 11 CORN COB, WALNUT SHELL

THE BASICS OF ABRASIVE BLASTING

SIX QUESTIONS TO ASK BEFORE CHOOSING AN ABRASIVE

1. FOR THIS PARTICULAR JOB, WILL ABRASIVE BLASTING BE USED FOR SURFACE PREPARATION OR AS A CLEANING PROCEDURE?

The difference between these two procedures is as follows:

- When abrasive blasting is used as a surface preparation technique, the intention is to both remove all surface contaminants and also prepare the substrate to receive a coating.
- When abrasive blasting is to be used as a cleaning procedure, then the intention is to remove only the surface contaminants, while leaving the substrate untouched.

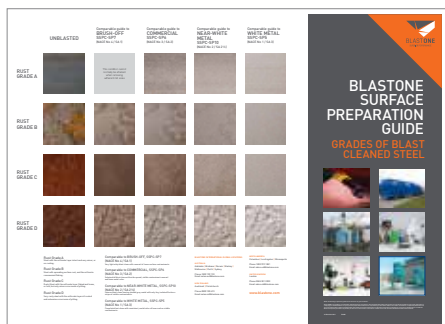

2. WILL IT BE POSSIBLE TO RECLAIM AND RECYCLE THE ABRASIVE, OR WILL IT HAVE A SINGLE USE ONLY?

The major deciding factor here is cost. The cost of abrasive varies widely and some abrasives, while very effective, are uneconomical to use if recycling is not an option.

3. WILL THE WORK SITE BE DUST SENSITIVE?

The amount of dust generated by different abrasives varies widely. Some excellent types of abrasive are available that are specifically graded to reduce dust.



4. IF BLASTING FOR SURFACE PREPARATION, WHAT SURFACE PROFILE IS REQUIRED?

All coatings have a recommended surface profile (roughness) specification. Excess surface profile can shorten the life of thin-film, low-build coatings; insufficient profile can cause delamination of high-build coatings.

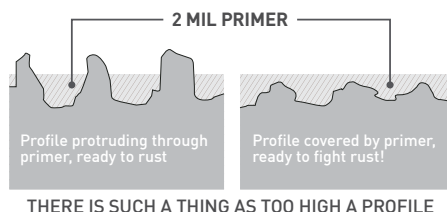

5. WILL COATING ADHESION BE AFFECTED BY SURFACE CONTAMINATION?

Some abrasives leave a cleaner surface than others, which can have a substantial impact on coating adhesion.

6. WHICH ABRASIVE PROVIDES THE MAXIMUM PRODUCTIVITY?

Abrasive particle size, toughness, and shape all have an effect on blasting speed. Some factors to consider:

- The ideal abrasive size is where the largest particle is equal in size to the thickness of the coating to be removed. If the particle size is too large, the "hit rate" is reduced because the grain count in the pot is lowered. If the particle size is too small, the speed of cutting through the old surface is reduced.
- Grain toughness is a term given to describe its durability and recyclability. A tougher grain converts more energy into the removal of the old coating, while a weaker grain is more likely to disintegrate on contact.
- Particle shape can either be rounded or angular. The more rounded the particle is, the more contact area it has, which increases the surface removal speed.

⚠ CAUTION ⚠

Blasting with silica sands, such as beach sand, river sand and any other crystalline silica sand may cause serious injury or be fatal. Crystalline silica is recognized world-wide as a Class 1 carcinogen.

Slag and coal abrasives have a traces of heavy metals like beryllium and arsenic which can find their way into the blasters respiratory system. Long-term or repeated exposure over years to the toxins has been linked to serious and life threatening health issues.

FIVE REASONS

WHY BLASTONE RECOMMENDS GMA GARNET FOR TOUGH JOBS

1

FASTER JOB COMPLETION

Removes tough coatings more than twice as fast as medium slag.

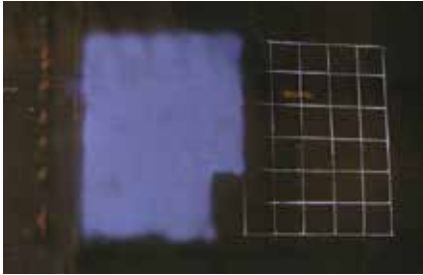

Slag – 10 minutes, 287 lbs used



ToughBlast Garnet – 10 minutes, 165 lbs used

2

LOWER COST TO USE

GMA Garnet delivers twice the blasting power of medium slag, and you use half as much.

Fewer hours of blasting expense.

TANK BLASTING PROFIT COMPARISON

Typical 45,000 sqft storage tank with coating over 15 mil

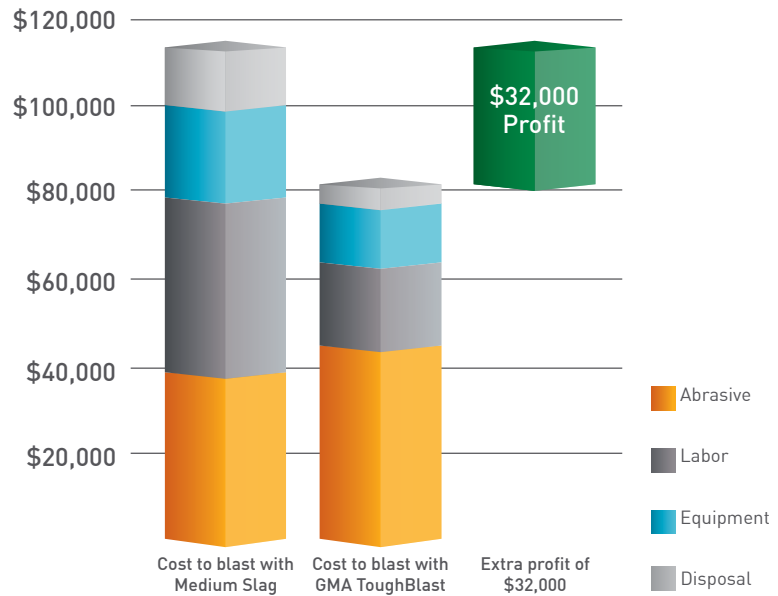

Want better profit with
GMA ToughBlast™?

Make sure your equipment, your settings
and your training is optimized.

Call BlastOne on 800 999 1881

3

LOW DUST

Provides dramatic dust reduction improving visibility by up to 10x for safer and more productive blasting.



Conventional abrasives can create excessive dust.



Blasting with GMA Garnet is much more neighborly.

4

BETTER QUALITY RESULTS

GMA Garnet gives you a cleaner surface, with no surface embedment which gives your new coating far better adhesion.

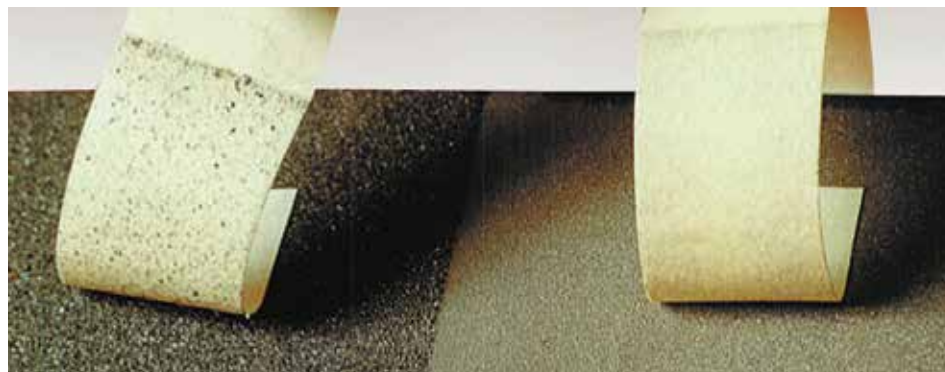

Slag

GMA SpeedBlast Garnet

5

LOWER ABRASIVE CONSUMPTION

- You use half as much
- Less clean up time
- Half your disposal costs

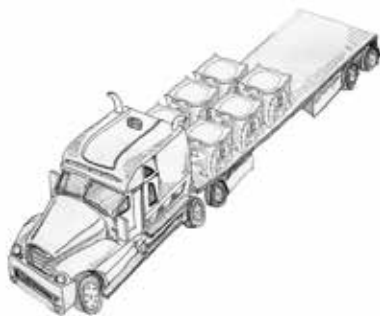

GMA SPEEDBLAST

Needed to blast this entire tank project
- 15 ton, 1 truck

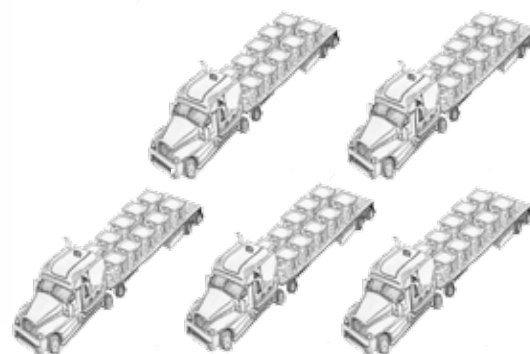

SLAG

Needed to blast this entire tank project
- 120 ton, 5 trucks

GMA ExtremeBlast



Ideal for TSA preparation, coatings for extreme conditions, preparing critical components. Removal of high build coatings, pliable and flexible coatings including coal tar, inner liners and some marine coatings. Suitable for offshore platform decking, tanks, piping, pressure vessels, ship hulls and ballast tanks.

A greater profile range can be achieved with exceptionally clean surface, enabling remarkable bonding of specialist coatings.

Blasting Speed	Up to 280 ft ² /hr
Dust factor	Low/Medium
Recyclability	4/10
Mesh Sizes	16,36
Profile Range	3.5-5.5 mil
Consumption Rate	2.5-3.5 lb/ft ²

Part Number	Description	Coating Thickness	Profile
GM16	16 Mesh Crushed Garnet Abrasive	100+ mil	4.0-5.5 mil
GM36	36 Mesh Crushed Garnet Abrasive	50-100 mil	3.5-5.0 mil
GX3	GX3 Garnet Abrasive	20-50 mil	3.5-5.0 mil

GMA ToughBlast



High performance 'all-around' garnet abrasive. Heavy industrial maintenance. Great on two coat systems, three coat systems and heavy mil (thick) rigid coatings.

Suitable for offshore platform decking, tanks, piping, pressure vessels, ship hulls and ballast tanks.

Blasting Speed	Up to 370 ft ² /hr
Dust factor	Low/Medium
Recyclability	4/10
Mesh Size	Blended grades
Profile Range	3.0-3.75 mil
Consumption Rate	1.5-3.0 lb/ft ²

Part Number	Description	Coating Thickness	Profile
GX2	GX2 Garnet Abrasive	15-40 mil	3.0-3.75 mil

GMA PremiumBlast



All-around' garnet abrasive. General industrial maintenance. For removal of medium coatings and/or medium-to-heavy rust.

Construction and maintenance of commercial buildings, chemical plants, power stations, mining and processing equipment, gas and sewerage plants, desalination and industrial plants. Tanks, piping, pressure vessels, ship hulls, ballast tanks and offshore platform decking.

Blasting Speed	Up to 340 ft ² /hr
Dust factor	Low
Recyclability	5/10
Mesh Sizes	30/60
Profile Range	3.0-3.75 mil
Consumption Rate	1.5-3.0 lb/ft ²

Part Number	Description	Coating Thickness	Profile
GA PB	Alluvial Garnet Abrasive	10-15 mil	3-3.75 mil
GM 3060	3060 Mesh Crushed Garnet Abrasive	10-15 mil	3-3.75 mil

GMA SpeedBlast



Light general industrial maintenance. Construction and maintenance of commercial buildings, chemical plants, power stations, mining and processing equipment, gas and sewerage plants, desalination and industrial plants.

Suitable for tanks, piping, pressure vessels, ship hulls, ballast tanks and offshore platform decking.

Blasting Speed	Up to 350 ft ² /hr
Dust factor	Low
Recyclability	5/10
Mesh Sizes	30/60, 80
Profile Range	2.5-3.5 mil
Consumption Rate	1.5-3.0 lb/ft ²

Part Number	Description	Coating Thickness	Profile
GASB	Alluvial Garnet Abrasive	5-10 mil	2.5-3.25 mil
GX1	GX1 Garnet Abrasive	10-15 mil	2.5-3.5 mil

GMA NewSteel



New construction; removal of light rust or mill scale on new steel. Removal and preparation for powder coating.

Suitable for tanks, piping, pressure vessels, ship hulls, ballast tank and offshore platform decking.

Blasting Speed	Up to 500 ft ² /hr
Dust factor	Low
Recyclability	6/10
Mesh Sizes	80
Profile Range	1.0-2.5 mil
Consumption Rate	1.25-2.0 lb/ft ²

Part Number	Description	Coating Thickness	Profile
GA NS	Alluvial Garnet Abrasive	Mill scale	1.5-2.0 mil
GX NS	GXNS Garnet Abrasive	Mill scale	1.25-2.0 mil
GM 80	80 Mesh Crushed Garnet Abrasive	Mill scale	1.5-2.5 mil

GMA PrecisionBlast



Preparing ferrous and non-ferrous metals and easily damaged or deformed substrates. Cleaning precision equipment like gages, turbines, propellers, valve bodies, threads (valves, bolts, pipes). Weld seam inspection.

Efficient alternative to hand tooling. Glass, fiberglass, plastics, softer metals, automobile, fire restoration and graffiti removal.

Blasting Speed	Up to 330 ft ² /hr
Dust factor	Low
Recyclability	10/10
Mesh Sizes	120, 200
Profile Range	0.75-2.0 mil
Consumption Rate	1.25-2.0 lb/ft ²

Part Number	Description	Coating Thickness	Profile
GA 120	120 Mesh Alluvial Garnet Abrasive	Specialty	1.0-2.0 mil
GA 200	200 Mesh Alluvial Garnet Abrasive	Specialty	0.75-1.5 mil

GMA SoftBlast



Suitable for automotive, marine, and antique restoration, log and old wood home restoration and graffiti removal.

Blasting Speed	Up to 300 ft ² /hr
Dust factor	Low
Recyclability	1/10
Mesh Sizes	350
Profile Range	0.5-0.75 mil
Consumption Rate	0.75-2.0 lb/ft ²

Part Number	Description	Coating Thickness	Profile
GA350	350 Mesh Alluvial Garnet Abrasive	Specialty	0.5-0.75 mil

INDIAN GARNET



Indian Garnet is mostly mined on the coasts of India. Typical sieve analysis will show coarser particle sizes between 12-60#.

Indian Garnet has a reputation for variable cleanliness, and salt and other contaminants are sometimes present.

Blasting Speed	Up to 220 ft ² /hr
Dust factor	Medium
Recyclability	2/10
Mesh Sizes	12/20, 20/40, 30/60, 80
Profile Range	1.5-4.5 mil
Consumption Rate	3.0-5.0 lb/ft ²

Part Number	Description	Coating Thickness	Profile
G1 1220	12/20 Mesh Indian Garnet	20+ mil	3.5-4.5 mil
G1 2040	20/40 Mesh Indian Garnet	15-20 mil	3.0-3.75 mil
G1 3060	30/60 Mesh Indian Garnet	10-15 mil	2.5-3.5 mil
G1 80	80 Mesh Indian Garnet	Mill scale	1.5-2.0 mil

CHINESE GARNET



As its name suggests, Crushed Garnet is a manufactured, rather than a natural, abrasive. In its original state, it is bound to other rock materials (such as granite) and must be crushed to separate it.

The effect of the crushing puts microscopic fracture lines in the particles, which makes them break apart when blasting. This creates a dusty blast, and means that the recyclability of this abrasive is negligible.

Blasting Speed	Up to 340 ft ² /hr
Dust factor	High
Recyclability	1/10
Mesh Sizes	20/40, 30/60, 80
Profile Range	1.5-3.75 mil
Consumption Rate	3.5-6.0 lb/ft ²

Part Number	Description	Coating Thickness	Profile
GG 2040	20/40 Mesh Crushed Chinese Garnet	15-20 mil	3.0-3.75 mil
GG 3060	30/60 Mesh Crushed Chinese Garnet	10-15 mil	2.5-3.5 mil
GG 80	80 Mesh Crushed Chinese Garnet	Mill scale	1.5-2.0 mil

COAL SLAG



Coal slag is a glass matrix alumina-silicate which is produced as a by-product of coal burning power plants. As the coal burns, the residual ash (slag) becomes molten. When this slag is cooled, it vitrifies into a glassy, abrasive material, which is then crushed to produce blast media. A wide range of mesh sizes are available, with some being capable of removing very thick or elastomeric coatings.

Blasting Speed	Up to 150 ft ² /hr
Dust factor	High
Recyclability	1/10
Mesh Sizes	10/40, 12/40, 20/40, 30/60, 60
Profile Range	2.0-5.0 mil
Consumption Rate	5.0-12.0 lb/ft ²

Part Number	Description	Coating Thickness	Profile
SL CAXC	10/40 Mesh 'Extra Coarse' Coal Slag	30 mil	4.0-5.0 mil
SL CAC	12/40 Mesh 'Coarse' Coal Slag	20-30 mil	3.5-4.5 mil
SL CAM	20/40 Mesh 'Medium' Coal Slag	10-20 mil	3.0-4.0 mil
SL CAF	30/60 Mesh 'Fine' Coal Slag	Mill scale	2.5-3.5 mil
SL CAXF	60 Mesh 'Fine' Coal Slag	Mill scale	2.0-3.0 mil

COPPER OR NICKEL SLAG



Metallic slags are produced from the by-products of the refining process. Similar to coal slag, the molten slag is rapidly cooled and the resulting material is crushed and screened. While metallic slags are slightly harder than coal slag, their performance and inherent issues are basically the same.

Metallic slags are primarily used in the geographic regions where their base metals are refined.

Blasting Speed	Up to 150 ft ² /hr
Dust factor	High
Recyclability	1/10
Mesh Sizes	12/30, 20/50, 30/60
Profile Range	2.5-4.5 mil
Consumption Rate	5.0-12.0 lb/ft ²

Part Number	Description	Coating Thickness	Profile
SL CUC	12/30 Mesh 'Coarse' Copper Slag	20-30 mil	3.5-4.5 mil
SL CUM	20/50 Mesh 'Medium' Copper Slag	10-20 mil	3.0-4.0 mil
SL CUF	30/60 Mesh 'Fine' Copper Slag	Mill scale	2.5-3.5 mil

STARBLAST/STAUROLITE



Staurolite is a mineral sand which is similar to garnet mineralogically, and has moderate levels of durability and hardness. Most Staurolite comes from Florida and Western Australia as a byproduct of the zircon mining process.

Low recyclability versus other media types means more abrasive is needed. Can be used for removal of mill scale and light rust.

Blasting Speed	Up to 300 ft ² /hr
Dust factor	High
Recyclability	1/10
Mesh Sizes	100
Profile Range	1.0-2.0 mil
Consumption Rate	2.0-3.0 lb/ft ²

Part Number	Description	Coating Thickness	Profile
ST DBSB	Dupont Starblast Abrasive	Mill scale	1.0-2.0 mil
ST PB	PowerBlast Staurolite Abrasive	Mill scale	1.0-2.0 mil

CRUSHED GLASS

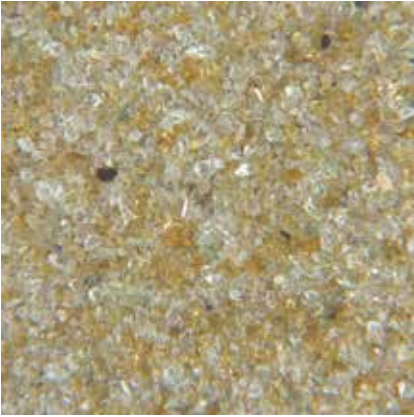

Crushed Glass is sourced from scrap glass containers. Being crushed, it is angular in shape and is available in larger sizes. It is mostly used for blasting very thick or elastomeric coatings.

Health warning – the glass is highly friable and particles are a physical irritant. May cause irritation to skin, eyes, nose, and throat.

Blasting Speed	Up to 220 ft ² /hr
Dust factor	Medium
Recyclability	1/10
Mesh Sizes	10/20, 10/40, 20/40, 40/70, 70/120
Profile Range	0.5-4.5 mil
Consumption Rate	3.5-7.5 lb/ft ²

Part Number	Description	Coating Thickness	Profile
1.411 mm	10/20 Mesh 'Extra Coarse' Crushed Glass	30+ mil	3.5-4.5 mil
CG C	10/40 Mesh 'Coarse' Crushed Glass	20-30 mil	3.5-4.5 mil
CG M	20/40 Mesh 'Medium' Crushed Glass	10-20 mil	2.5-3.5 mil
CG F	40/70 Mesh 'Fine' Crushed Glass	Mill scale	1.0-2.5 mil
CG XF	70/70 Mesh 'Extra Fine' Crushed Glass	Mill scale	0.5-1.5 mil

GLASS BEADS

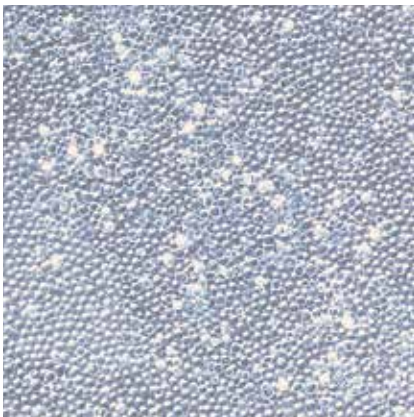

Glass beads are a manufactured abrasive. The spherical shape prevents impingement.

Glass bead is a low-impact media that can be used for a variety of cleaning applications and surface treatments.

Used where profiling of substrate is undesirable.

Blasting Speed	Up to 40 ft ² /hr
Dust factor	N/A
Recyclability	7/10
Mesh Size Range	20-325
Profile Range	0.25-1.0 mil
Consumption Rate	N/A

Part Number	Description	Coating Thickness	Profile
ASGB3	20/30 mesh Glass Beads – B3	Polishing	0.25-1.0 mil
ASGB4	30/40 mesh Glass Beads – B4	Polishing	0.25-1.0 mil
ASGB5	40/50 mesh Glass Beads – B5	Polishing	0.25-1.0 mil
ASGB6	50/70 mesh Glass Beads – B6	Polishing	0.25-1.0 mil
ASGB7	60/80 mesh Glass Beads – B7	Polishing	0.25-1.0 mil
ASGB8	70/100 mesh Glass Beads – B8	Polishing	0.25-1.0 mil
ASGB9	80/120 mesh Glass Beads – B9	Polishing	0.25-1.0 mil
ASGB10	100/170 mesh Glass Beads – B10	Polishing	0.25-1.0 mil
ASGB11	120/200 mesh Glass Beads – B11	Polishing	0.25-1.0 mil
ASGB12	140/230 mesh Glass Beads – B12	Polishing	0.25-1.0 mil
ASGB13	170/325 mesh Glass Beads – B13	Polishing	0.25-1.0 mil

BROWN ALUMINUM OXIDE



Aluminum Oxide is a manufactured abrasive, specifically designed for sharpness and hardness. It is available in two different grades of purity. Brown Aluminum Oxide is for general industrial usage and the white version is used in sanitary applications. The sharpness and hardness of this abrasive will leave a very pronounced profile.

Often used for surface preparation prior to plating, metal spraying or ceramic coating, and can be used both on both steel as well as on Aluminum or non-ferrous alloys.

Blasting Speed	40-200 ft ² /hr
Dust factor	Low
Recyclability	7/10
Mesh Size Range	8-250
Profile Range	0.25-6.0 mil
Consumption Rate	N/A

Part Number	Description	Coating Thickness	Profile
SUALOXB008	8 Mesh Brown Aluminum Oxide	Specialty	5.0 - 6.0 mil
SUALOXB012	12 Mesh Brown Aluminum Oxide	Specialty	5.0 - 5.5 mil
SUALOXB016	16 Mesh Brown Aluminum Oxide	Specialty	5.0 - 5.5 mil
SUALOXB024	24 Mesh Brown Aluminum Oxide	Specialty	4.0-5.0 mil
SUALOXB030	30 Mesh Brown Aluminum Oxide	Specialty	4.0-5.0 mil
SUALOXB036	36 Mesh Brown Aluminum Oxide	Specialty	3.5-4.5 mil
SUALOXB046	46 Mesh Brown Aluminum Oxide	10-30 mil	3.5-4.5 mil
SUALOXB054	54 Mesh Brown Aluminum Oxide	10-30 mil	2.5-3.5 mil
SUALOXB060	60 Mesh Brown Aluminum Oxide	Mill scale	2.0-3.0 mil
SUALOXB080	80 Mesh Brown Aluminum Oxide	Mill scale	1.0-2.0 mil
SUALOXB100	100 Mesh Brown Aluminum Oxide	Mill scale	1.0-2.0 mil
SUALOXB120	120 Mesh Brown Aluminum Oxide	Mill scale	0.5-1.0 mil
SUALOXB150	150 Mesh Brown Aluminum Oxide	Specialty	0.5-1.0 mil
SUALOXB180	180 Mesh Brown Aluminum Oxide	Specialty	0.25-0.75 mil
SUALOXB220	220 Mesh Brown Aluminum Oxide	Specialty	0.25-0.75 mil
SUALOXB240	240 Mesh Brown Aluminum Oxide	Specialty	0.25-0.75 mil
SUALOXB280	280 Mesh Brown Aluminum Oxide	Specialty	0.25-0.5 mil

STEEL GRIT



Steel Grit is a recycled product manufactured from scrap steel. This scrap is melted down, reformed and crushed.

Typically used in blast rooms and in large steel grit recycling units, often found in the bridge repair industry.

Blasting Speed	Up to 120 ft ² /hr
Dust factor	Low
Recyclability	10/10
Mesh Sizes	25, 40, 50, 40/50, 80
Profile Range	2.0-5.0 mil
Consumption Rate	N/A

Part Number	Description	Coating Thickness	Profile
AM GL25	25 Mesh Steel Grit	40+ mil	4.0-5.0 mil
AM GL40	40 Mesh Steel Grit	20-40 mil	3.5-4.5 mil
AM GL50	50 Mesh Steel Grit	10-30 mil	3.0-4.5 mil
AM GL80	80 Mesh Steel Grit	Mill scale	2.0-3.5 mil
AMGL4050	40/50 Mesh Steel Grit	15-40 mil	3.0-4.5 mil

STEEL SHOT



Steel shot is popular in airless wheel machines, in part because it is less destructive to the machine than other abrasive types.

Used in wheel machines for shot peening and cleaning applications.

Blasting Speed	Up to 50 ft ² /hr
Dust factor	Low
Recyclability	10/10
Mesh Size Range	S780-S70
Profile Range	0.5-1.0 mil
Consumption Rate	N/A

Part Number	Description	Mesh	Coating Thickness	Profile
AM S460	S460 Steel Shot	16/18	Peening	0.5-1.0 mil
AM S390	S390 Steel Shot	18/20	Peening	0.5-1.0 mil
AM S330	S330 Steel Shot	20/25	Peening	0.5-1.0 mil
AM S280	S280 Steel Shot	25/30	Peening	0.5-1.0 mil
AM S230	S230 Steel Shot	30/35	Peening	0.5-1.0 mil
AM S170	S170 Steel Shot	40/45	Peening	0.5-1.0 mil
AM S110	S110 Steel Shot	50/80	Peening	0.5-1.0 mil

SODIUM BICARBONATE



The most common application for Sodium Bicarbonate is as a degreaser or for paint removal on a soft substrate. Ideal for graffiti removal, cleaning of brickwork, cleaning automobiles and very thin coatings.

Available in many different formulations (rather than different sizing) – for different applications.

Blasting Speed	Up to 100 ft ² /hr
Dust factor	Medium
Recyclability	Non-recyclable
Mesh Sizes	270
Profile Range	0.25-2.0 mil
Consumption Rate	1.0-2.0 lb/ft ²

Part Number	Description	Coating Thickness	Profile
AR XMaintenanceXL	Maintenance Grade Soda	1.0-5.0 mil	0.25-0.5 mil
AR XFlowXL	Formulated Soda for Humid Areas	1.0-5.0 mil	0.25-0.5 mil
AR XProfileXL	Formulated Soda with Grit	2.0-10.0 mil	1.0-2.0 mil
AR XSodeX	Sodium Bicarbonate Media	1.0-5.0 mil	0.25-0.5 mil

CORN COB



Corn Cob abrasive is ideal for deburring and polishing, often used to remove mold, smoke and fire damage. Can be used on operating machinery, will not damage glass or rubber.

Blasting Speed	Up to 100 ft ² /hr
Dust factor	Low
Recyclability	1/10
Mesh Sizes	10/14, 14/20, 20/40
Profile Range	0.25-0.5 mil
Consumption Rate	2.0-6.0 lb/ft ²

Part Number	Description	Coating Thickness	Profile
SU CC1014	10/14 Mesh Corn Cob Media	Polishing	0.25-0.5 mil
SU CC1420	14/20 Mesh Corn Cob Media	Polishing	0.25-0.5 mil
SU CC2040	20/40 Mesh Corn Cob Media	Polishing	0.25-0.5 mil

WALNUT SHELL



Walnut Shell has excellent durability, and is now widely used to blast clean and polish soft metals, glass, fiberglass, wood, plastic and stone.

Walnut Shell works as a de-burring and de-flashing product for moulding, casting and electrical parts.

Blasting Speed	Up to 100 ft ² /hr
Dust factor	Low
Recyclability	1/10
Mesh Sizes	8/12, 12/20, 20/30, 40/100
Profile Range	0.25-0.5 mil
Consumption Rate	2.0-6.0 lb/ft ²

Part Number	Description	Coating Thickness	Profile
SU WALNUT0812	8/12 Mesh Walnut Shell Media	Polishing	0.25-0.5 mil
SU WALNUT1220	12/20 Mesh Walnut Shell Media	Polishing	0.25-0.5 mil
SU WALNUT2030	20/30 Mesh Walnut Shell Media	Polishing	0.25-0.5 mil
SU WALNUT40100	40/100 Mesh Walnut Shell Media	Polishing	0.25-0.5 mil

ABRASIVE SHIPPING LOCATIONS



DISCLAIMER: The performance characteristics provided in this brochure only serves as a guide and that the results can vary widely on every project. Let BlastOne assist you on using the right abrasive and the right equipment for every project.

While care has been taken in compiling these notes, no responsibility is accepted by the compiler for any damage or loss, caused to anyone or any company accepting the advice or suggestion contained herein. It is your responsibility to be aware of regulations which Local, State, or Federal Government authority may impose.

©Copyright BlastOne 2017. All rights reserved.

The entire contents of this booklet are copyright. Photocopying, scanning, duplications or copying of pictures or information (except as permitted under the Copyright Act) is a breach of copyright and may result in legal action.

No part of this booklet may be reproduced or transmitted in any form or by any means, electronic, mechanical, photocopying, recording, or otherwise, without prior written permission of BlastOne.



BLASTONE INTERNATIONAL

4510 Bridgeway Avenue
Columbus Ohio 43219 USA

Toll Free 800 999 1881
Tel (614) 476 3000
Fax (614) 476 3002
Email sales.na@blastone.com
www.blastone.com

AUSTRALIA

Adelaide | Brisbane | Darwin |
Mackay | Melbourne | Perth | Sydney

NEW ZEALAND

Auckland | Christchurch

NORTH AMERICA

Columbus | Los Angeles |
Minneapolis

UNITED KINGDOM

London